

RESEARCH OUTPUTS / RÉSULTATS DE RECHERCHE

The uniqueness of ABCB5 as a full transporter ABCB5FL and a half-transporter-like ABCB5 β

Gerard, Louise; Gillet, Jean Pierre

Published in:
Cancer Drug Resistance

DOI:
[10.20517/cdr.2024.56](https://doi.org/10.20517/cdr.2024.56)

Publication date:
2024

Document Version
Publisher's PDF, also known as Version of record

[Link to publication](#)

Citation for published version (HARVARD):

Gerard, L & Gillet, JP 2024, 'The uniqueness of ABCB5 as a full transporter ABCB5FL and a half-transporter-like ABCB5 β ', *Cancer Drug Resistance*, vol. 7, 29. <https://doi.org/10.20517/cdr.2024.56>

General rights

Copyright and moral rights for the publications made accessible in the public portal are retained by the authors and/or other copyright owners and it is a condition of accessing publications that users recognise and abide by the legal requirements associated with these rights.

- Users may download and print one copy of any publication from the public portal for the purpose of private study or research.
- You may not further distribute the material or use it for any profit-making activity or commercial gain
- You may freely distribute the URL identifying the publication in the public portal ?

Take down policy

If you believe that this document breaches copyright please contact us providing details, and we will remove access to the work immediately and investigate your claim.

Review

Open Access



The uniqueness of ABCB5 as a full transporter ABCB5FL and a half-transporter-like ABCB5 β

Louise Gerard, Jean-Pierre Gillet 

Laboratory of Molecular Cancer Biology, URPhyM, NARILIS, University of Namur, Namur 5000, Belgium.

Correspondence to: Prof. Jean-Pierre Gillet, Laboratory of Molecular Cancer Biology, URPhyM, NARILIS, University of Namur, Rue de Bruxelles 61, 5000 Namur, Belgium. E-mail: jean-pierre.gillet@unamur.be

How to cite this article: Gerard L, Gillet JP. The uniqueness of ABCB5 as a full transporter ABCB5FL and a half-transporter-like ABCB5 β . *Cancer Drug Resist* 2024;7:29. <https://dx.doi.org/10.20517/cdr.2024.56>

Received: 3 May 2024 **First Decision:** 3 Jul 2024 **Revised:** 26 Jul 2024 **Accepted:** 1 Aug 2024 **Published:** 7 Aug 2024

Academic Editors: Liwu Fu, Zhesheng Chen **Copy Editor:** Dong-Li Li **Production Editor:** Dong-Li Li

Abstract

The *ABCB5* gene encodes several isoforms, including two transporters (i.e., ABCB5FL, ABCB5 β) and several soluble proteins, such as ABCB5 α which has been hypothesized to have a regulatory function. ABCB5FL is a full ABC transporter and is expressed in the testis and prostate, whereas ABCB5 β is an atypical half-transporter with a ubiquitous expression pattern. ABCB5 β has been shown to mark cancer stem cells in several cancer types. In addition, ABCB5 β and ABCB5FL have been shown to play a role in tumorigenesis and multidrug resistance. However, ABCB5 β shares its entire protein sequence with ABCB5FL, making them difficult to distinguish. It cannot be excluded that some biological effects described for one transporter may be mediated by the other isoform. Therefore, it is difficult to interpret the available data and some controversies remain regarding their function in cancer cells. In this review, we discuss the data collected on ABCB5 isoforms over the last 20 years and propose a common ground on which we can build further to unravel the pathophysiological roles of ABCB5 transporters.

Keywords: ABC transporter, half-transporter, multidrug resistance, cancer stem cells

INTRODUCTION

ABCB5 was first identified in 1996 and named HuMDR3 after mapping of ABC transporter genes using the human-expressed sequence tags database, which reports cDNA sequences from various tissues representing the human transcriptome^[1]. This ABC transporter homolog was identified on chromosome 7^[1] and first



© The Author(s) 2024. **Open Access** This article is licensed under a Creative Commons Attribution 4.0 International License (<https://creativecommons.org/licenses/by/4.0/>), which permits unrestricted use, sharing, adaptation, distribution and reproduction in any medium or format, for any purpose, even commercially, as long as you give appropriate credit to the original author(s) and the source, provide a link to the Creative Commons license, and indicate if changes were made.



cloned seven years later by Frank *et al.* from human epidermal melanocytes (HEM)^[2]. This transporter, first named ABCB5 P-gp and later ABCB5 β , was shown to influence membrane potential in progenitor cells, which regulated their fusion^[2]. Soon after, additional transcripts were cloned, including ABCB5 α ^[3], ABCB5.e^[4], and ABCB5.ts for testis-specific, also named ABCB5FL for full-length^[5,6]. According to the AceView program^[7], which provides a strictly cDNA-supported view of the human transcriptome and genes, transcription of the *ABCB5* gene results in 11 transcript variants [Table 1].

The two longest transcripts, ABCB5FL and ABCB5 β , are transcribed from two different promoters, as reported in ZENBU, a genome browser for transcriptomic and epigenetic data^[8]. The other shorter transcripts, resulting from alternative RNA splicing, are most likely derived from ABCB5 β transcription, as their tissue localization overlaps. They encode soluble proteins whose function remains to be elucidated.

ABCB5FL has the typical topology of a full ABC transporter. It is composed of two transmembrane domains (TMDs), each consisting of six transmembrane helices (TMHs), and two nucleotide-binding domains (NBDs) [Figure 1]^[9]. The TMDs contain the drug binding site, responsible for the interaction with the substrate and are therefore responsible for substrate specificity^[10]. NBDs are composed of an A-Loop, Walker A, Q-Loop, ABC signature motif, Walker B, D-Loop, and H-Loop [Figure 1]. These conserved motifs are responsible for ATP binding and hydrolysis, interaction between NBDs, and communication between NBDs and TMDs^[10]. ABCB5 β is an atypical half-ABC transporter that harbors an additional NBD in its N-terminus that lacks the A-loop and the Walker A motif involved in ATP binding and hydrolysis [Figure 1]^[11]. Although ABCB5 β was originally predicted to have an extracellular NBD followed by five α -helices and an intracellular NBD^[2], two independent studies proposed a more conventional topology consisting of a TMD spanned by six α -helices and two intracellular NBDs^[11,12]. ABCB5 β must either homodimerize or heterodimerize to become functional, and dimerization motifs have been identified in its N-terminal region^[11]. Recently, our group has shown that the ABCB5 β homodimer has a basal ATPase activity that can be inhibited by beryllium fluoride^[12]. However, the impact of the truncated NBD on the function and expression of the transporter remains to be determined. In this study, we also demonstrated that ABCB5 β can heterodimerize with ABCB6 and ABCB9, two other half-ABC transporters, in two melanoma cell lines^[12]. Chimeric heterodimers showed that ABCB5 β /B6 and ABCB5 β /B9 have a basal ATPase activity that was reduced by a point mutation, E to Q, in their Walker B motifs^[12]. This mutation in the Walker B of one transporter or mutations in the Walker B of both interacting partners had the same effect on ATP hydrolysis, suggesting that both transporters are required for ATP hydrolysis^[12]. It is important to note that even though ABCB5 β dimers have basal ATPase activity, there is, so far, no evidence for the physiological relevance of these proteins, and complementary investigations are needed (See Section “ABCB5 physiological function and pathophysiology” for more details).

Overall, ABCB5 isoforms remain little described in the literature and some information is misleading for three main reasons. (1) Conventional techniques (i.e., Western blotting, RT-qPCR, immunofluorescence, and immunohistochemistry) do not always allow to distinguish between the different isoforms; (2) confusion between the two longest isoforms can be seen in many publications; and (3) most of them do not mention the isoform studied. However, ABCB5FL and ABCB5 β have different characteristics, as presented in the following section of this review, suggesting that they have different functions. This review proposes to establish common ground by describing seminal information that will help to reconcile the diverse and often disparate literature on ABCB5 transporters.

EVOLUTION OF THE *ABCB5* GENE

ABCB full transporters are derived from a single gene that is also present in non-vertebrates such as

Table 1. Transcript variants of ABCB5

Given name	AceView program	Amino acids	Ref.
ABCB5.ts, ABCB5FL (full length)	ABCB5.a	1,257	[5,6]
ABCB5 β	ABCB5.b	812	[2,3]
	ABCB5.c	313	
	ABCB5.d	209	
	ABCB5.e	134	[4]
	ABCB5.f	129	
	ABCB5.g	63	
ABCB5 α	ABCB5.h	131	[3,4]
	ABCB5.i	126	
	ABCB5.j	46	
	ABCB5.k	17	

Drosophila, *C. elegans*, and yeast^[11]. In addition to ABCB5, the B family consists of three full transporters (i.e., ABCB1, ABCB4, and ABCB11) and seven half transporters (i.e., ABCB2, ABCB3, ABCB6, ABCB7, ABCB8, ABCB9, and ABCB10). Phylogenetic analysis revealed that ABCB5 is closely related to ABCB1, ABCB4, and ABCB11. ABCB5 homologs have been identified in mice, rats, pigs, chickens, geese, guppies, zebrafish, and earthworms^[13,14]. ABCB5 shares 73% homology with ABCB1^[15]. However, in zebrafish, ABCB5 homolog (*abcb5*) did not transport several ABCB1 substrates, and ABCB4 homolog (*abcb4*) was shown to have an increased overlapping substrate specificity with ABCB1 than *abcb5*^[16].

The phylogenetic and evolutionary analysis by Moitra *et al.* showed that ABCB5 has evolved as a full transporter for most of its evolutionary history^[11]. Therefore, it remains puzzling why, at least in humans, ABCB5 also exists as a half-transporter. Ford *et al.* suggested that because ABCB half-transporters are localized in organelles (i.e., mitochondria, lysosomes, and endoplasmic reticulum), it is easier for them to find their interacting partner, thus obviating the need for internal liaison between these proteins^[17]. On the other hand, full ABCB transporters localize to the plasma membrane. For these transporters, a fusion of the two halves may have occurred to simplify their assembly in response to the increasing complexity of the eukaryotic cell^[17]. However, this hypothesis is not supported for the ABCG family, where ABCG half-transporters localize to the plasma membrane. Another explanation could be that ABC half-transporters have persisted throughout evolution because they have different interacting partners, with each dimer exerting different functions. Several ABC half-transporters from different families have been shown to interact with each other^[12]. Although the biological relevance of these interactions remains to be elucidated, it is likely that each dimer has a different function.

HEALTHY TISSUES AND INTRACELLULAR LOCALIZATION

ABCB5FL was cloned from a human testis cDNA library, and its expression was detected only in testis and prostate. ABCB5 β was cloned from human epidermal melanocyte mRNA but shows a broader tissue expression [Figure 2A]^[2,5,6]. Saeed *et al.*^[18-21] obtained similar results using immunohistochemistry on human tissue^[13]. They showed that ABCB5 β expression is strongest in stalk polyps from the colon, hepatocytes, portal vein, and bile duct, maternal decidua in the placenta and follicles, and thyroid parafollicular cells^[13]. Furthermore, Jongkhajornpong *et al.* used immunostaining to show that ABCB5 expression in the eye is located in the palisade of Vogt in the basal epithelial layer of the corneal limbus^[22]. Using immunostaining and *in situ* hybridization, ABCB5 expression in the placenta was observed in villous trophoblasts of first-trimester placentas, partial moles, and complete moles^[23]. However, to our knowledge, none of these studies used an antibody whose validation has been reported in the literature [Table 2]^[24]. It is important to

Table 2. Anti-ABCB5 antibodies and their validation

Antibody information	Epitope ABCB5 β	Epitope ABCB5FL	Validation	Concern regarding the localization data
A Mouse monoclonal (Catalog number MABC711MI, ThermoFisher Scientific)	aa. 481-674	aa. 926-1119	Western blot with siRNA targeting ABCB5, no decrease in protein level ^[25]	No negative control on the Western blot and no mention of the molecular weight studied. Furthermore, the epitope is localized in the phospholipid bilayer and therefore is not accessible to the antibody by immunohistochemistry ^[13]
Rabbit polyclonal (Catalog number NBP1-50547x500, Novus Biologicals)	aa. 1-30	aa. 446-475	Western blot comparing protein lysate from Abcb5 wild-type and Abcb5 KO mice. No mention of the molecular weight observed, weak signal for the wild type, and no mention of the tissue of origin of the cells lysed and used for Western blotting ^[24]	The negative control is only an isotype control, i.e., an antibody that has no specificity for the intended target ^[22] . This type of control is used to discriminate signal from background noise, but it does not validate the specificity of the antibody used, as discussed in ref ^[26] . A better control would be the use of knock-out or knock-down cell lines or tissues that do not express the protein of interest
3C2-1D12 (not commercially available)	aa. 493-508	aa. 938-953	Western blot comparing cells transfected with ABCB5 β and non-transfected cells, but no loading control is shown on the Western blot gel ^[2]	No negative control for the immunohistochemistry was performed with the antibody ^[23]
A Rabbit polyclonal (Catalog number SAB1300315, Sigma)	N-terminus		Western blot with siRNA targeting ABCB5, no decrease in protein level ^[25]	
A Goat polyclonal (Catalog number ab77549, Abcam)	aa. 460-471	aa. 907-918	Western blot with siRNA targeting ABCB5, no decrease in protein level ^[25]	
B Rabbit polyclonal (Catalog number ab80108, Abcam)	aa. 1-99	aa. 446-545	Western blot and immunofluorescence after using siRNA targeting ABCB5, no decrease in protein level ^[19]	
B Rabbit polyclonal (Catalog number 600-401-A77, Rockland)	aa. 192-208	aa. 637-653	Western blot and immunofluorescence after using siRNA targeting ABCB5, no decrease in protein level ^[19]	
B Rabbit polyclonal (Catalog number Hpa026975, Atlas Antibodies)	aa. 145-234	aa. 590-679	Western blot and immunofluorescence after using siRNA targeting ABCB5, no decrease in protein level ^[19]	

This table shows the antibodies used to detect ABCB5 along with the position of their epitope in the amino acid sequence of both ABCB5 β and ABCB5FL isoforms and their proposed validation in the literature. The rows labeled A and B represent the antibodies for which Louphrasitthiphol *et al.* and Díaz-Anaya *et al.* demonstrated a lack of specificity using siRNAs against ABCB5 and Western blotting^[19,25]. This table purposely presents exclusively antibodies used to study ABCB5 localization or questioned in ref^[19,25].

emphasize that the main challenge in studying ABCB5 is the specificity of anti-ABCB5 antibodies. Louphrasitthiphol *et al.* were able to decrease ABCB5 mRNA using siRNA, while they were unable to detect a decrease in the levels of the major bands detected by Western blotting using three commercially available anti-ABCB5 antibodies [Table 2, row A]^[25]. In another study, Díaz-Anaya *et al.* encountered similar problems. A pool of four siRNAs targeting ABCB5 resulted in a greater than 90% decrease in ABCB5 mRNA. However, no decrease in signal was observed by Western blotting and immunofluorescence

ABCB5 FL**ABCB5 β** 

Figure 1. Topology of ABCB5FL and ABCB5 β . Two-dimensional representation of the topology of ABCB5FL and ABCB5 β based on CCTOP prediction^[9]. ABCB5FL is composed of 12 TMH (shown in blue) and two NBD (shown in orange). The NBDs are composed of an A-Loop, Walker A, Q-Loop, signature motif, Walker B, D-Loop, and H-Loop; the amino acid sequences are detailed in the corresponding boxes. ABCB5 β consists of 6 TMHs and two NBDs. The N-terminal NBD lacks the A-Loop and the Walker A motif. CCTOP: Consensus Constrained TOPology prediction; TMH: transmembrane helix; NBD: nucleotide-binding domain.

using three commercially available anti-ABCB5 antibodies [Table 2, row B]^[19]. Since both studies examined ABCB5 expression 96 h after siRNA transfection, it is very unlikely that the signal in Western blotting is due to residual ABCB5 protein expression. These results call into question the specificity of the antibodies tested and show that we must remain vigilant regarding data published exclusively with anti-ABCB5 antibodies^[19,25]. Overall, there is a need for standardized methods to validate antibody specificity, and we propose a strategy based on the five pillars proposed by Uhlen *et al.* being genetic validation (using siRNA, shRNA or CRISPR controls), orthogonal validation (comparison with an antibody-independent technique), antibody comparison (comparison with another validated antibody targeting the same protein), validation with a tag (comparison with results obtained using tagged version of the protein of interest), and validation through immunocapture of the target protein followed by mass spectrometry analysis of its expression^[27,28].

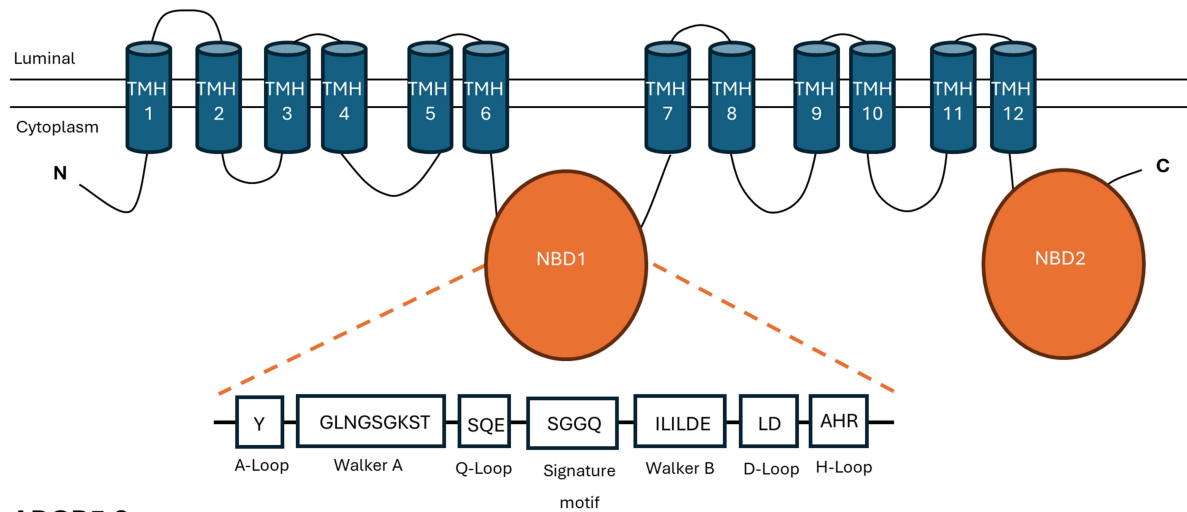
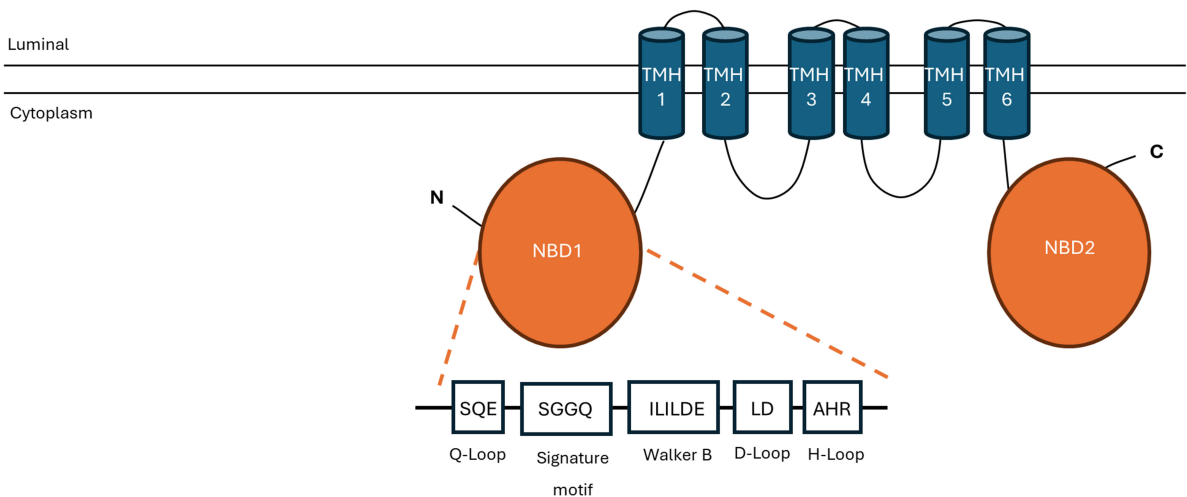
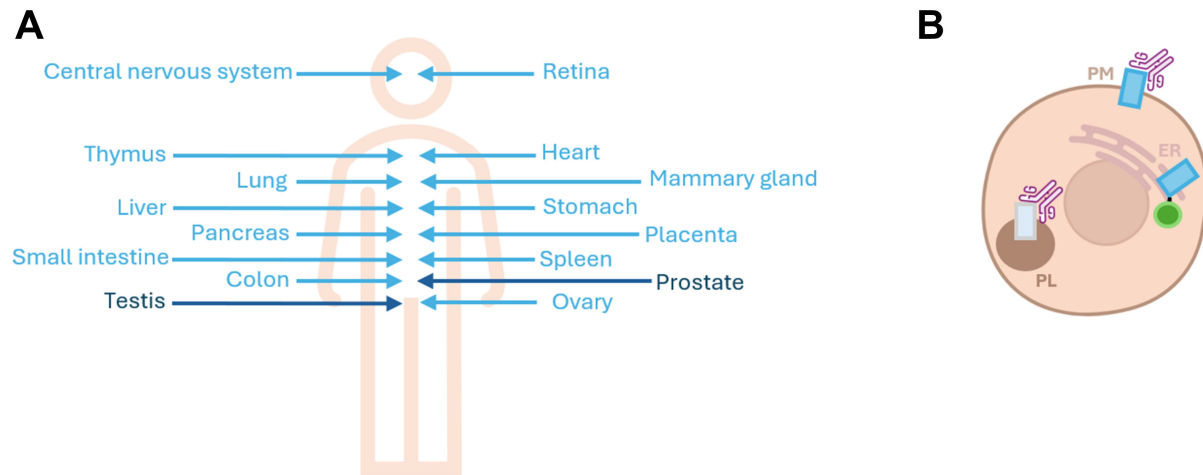

Figure 2. Tissue and intracellular localization of ABCB5FL and ABCB5 β . (A) Representation of human ABCB5 tissue localization based on ABCB5FL and ABCB5 β mRNA detection from^[1,6,18]. Light blue represents ABCB5 β localization. Dark blue represents ABCB5FL localization; (B) Schematic representation of the proposed intracellular localization of ABCB5 in light blue^[2,19,20] and one of the two longest isoforms in gray^[21]. Results obtained using antibodies, for which more validation is necessary, are highlighted by a pink antibody. Results obtained with tagged protein are highlighted by a green round schematizing a GFP tag. PM: Plasma membrane; ER: endoplasmic reticulum; PL: phagolysosomes; GFP: green fluorescent protein.

To our knowledge, the lack of validation for anti-ABCB5 is not limited to the antibodies used to investigate ABCB5 localization [Table 2], but it is the same for the remaining literature on this transporter. In consequence, all conclusions published using exclusively antibodies must be carefully taken into account. For the experiments presented in the following Sections, the antibody catalog number and the names of the companies are mentioned to remind the reader of this important limitation.

ABCB5 homologs are also ubiquitously expressed in other vertebrates. In zebrafish, *abcb5* was detected in liver, kidney, skin, ovary, and gill using a combination of RNAscope and immunohistochemistry^[16]. Interestingly, *abcb5* expression in the ovary was detected in early follicular stages but not in later stages. Similarly, *abcb5* expression was detected by *in situ* hybridization in the gills of juvenile rainbow trout, and its expression was restricted to the interlamellar space of the gills, known to contain progenitor cells^[29]. However, *abcb5* expression was not detected in trout liver, kidney, or blood^[29]. Using immunofluorescence, Saeed *et al.* detected *abcb5* expression in the liver of mice, rats, pigs, and chickens^[13]. In mice, the colon, brain, testes, liver, spleen, kidney, and pancreas had the highest *abcb5* expression^[13].

Regarding the intracellular localization of ABCB5 [Figure 2B], Frank *et al.* showed, by indirect surface immunostaining and flow cytometry of non-permeabilized MCF-7 transfected with ABCB5 β , that ABCB5 β was localized to the plasma membrane compared to untransfected MCF-7^[2]. Although the percentage of ABCB5 β expression at the plasma membrane compared to untransfected cells was similar to the transfection rate of this transporter, the Western blotting data used to validate the antibody lacks a loading control necessary to confirm the specificity of this antibody [Table 2]. Subsequently, 14 N-glycosylation sites were found in ABCB5FL, two of which (amino acids 85-88 and 91-94) may be important for plasma membrane targeting^[11]. Indeed, N-glycosylation has been shown to be necessary for the trafficking of several proteins to the plasma membrane, and the mentioned amino acids are of particular interest due to their position in the ABCB5 sequence^[30]. In addition, 6 N-glycosylation sites have been found in ABCB5 β , one of which (amino acids 374-377) may be important for plasma membrane targeting^[11]. Chartrain *et al.* also identified ABCB5 expression at the plasma membrane by flow cytometry in several melanoma cell lines^[20]. They used siRNA

against ABCB5 as a negative control and performed their experiment with two different antibodies (600-401-A77 from Rockland and 3C2-1D12 not commercially available) with controversial results in other publications [Table 2]. It is important to note that in this flow cytometry experiment, the cells were not permeabilized, i.e., the antibody used should stain the protein at the cell surface. However, the epitope of 600-401-A77 antibody from Rockland is located at amino acids 192-208 of the ABCB5 β sequence (i.e., NBD1), which is thought to be in the cytoplasm, and the epitope of 3C2-1D12 antibody which is not commercially available is located at amino acids 493-508 of the ABCB5 β sequence (i.e., the fifth extracellular loop), which is thought to be located outside the cells [Table 2]. Since both epitopes are located on opposite sides of the membrane, it would not have been possible to localize ABCB5 β to the plasma membrane by flow cytometry, without permeabilization, by the two antibodies, as suggested by the authors^[20]. In contrast, Díaz-Anaya *et al.* identified ABCB5 β in the endoplasmic reticulum after transfection in HELA and MelJuSo^[19]. They used a green fluorescent protein (GFP) tag, but several controls were performed to ensure that no mislocalization resulted from the use of this tag. These controls include the localization of GFP-ABCB9, as this transporter localization has already been described in the literature, the use of a smaller tag (HA tag), and the use of a low expression promoter. Cell surface biotinylation in HELA cells showed no expression of labeled ABCB5 β at the plasma membrane^[19]. In another study, ABCB5 was identified by immunofluorescence in phagolysosomes of human monocyte-derived macrophages infected with *Leishmania braziliensis*^[21]. However, no negative controls were used in this experiment and the reference to the anti-ABCB5 antibody was not mentioned. It is important to point out that the mentioned studies were performed in different cell types and with different techniques, which could be responsible for the different localizations obtained. Overall, the data suggest that ABCB5 β localizes in the endoplasmic reticulum, and it is not excluded that after expression in this organelle, ABCB5 β traffics to the plasma membrane or to another organelle, although further confirmation on this point is needed. However, our team did not detect its expression at the plasma membrane after cell surface biotinylation in transiently transfected HELA cells. Furthermore, the intracellular localization of ABCB5FL and the other soluble isoforms (including ABCB5 α) remains to be elucidated.

ABCB5 AS A MARKER OF STEM CELLS AND CANCER STEM CELLS

Stem cells

Stem cells have the unique ability to self-renew and differentiate into any cell of an organism. Interestingly, ABCB5 β was first identified as a marker of skin progenitor cells^[2]. Later, ABCB5 was shown to mark a stem cell subpopulation in several tissues. In the eye, ABCB5 was shown to be a marker of limbal stem cells^[24]. Ksander *et al.* showed that *Abcb5* KO mice have impaired corneal development and corneal restoration after injury^[24]. They demonstrated that human and mouse ABCB5⁺ limbal stem cells were able to regenerate the cornea in a syngeneic mouse model of limbal stem cell deficiency^[24]. More recently, this group and others have shown that human ABCB5⁺ limbal stem cells derived from cadaveric corneal tissue can be expanded. Further non-clinical development supported advancement into a clinical trial (NCT03549299) for the treatment of limbal stem cell deficiency^[31]. Interestingly, *Abcb5* KO mice, used to study ABCB5 implication in corneal development, had no visible phenotypical change from litter to adulthood compared to their wild-type counterpart^[24]. In another study, *Abcb5* KO mice treated with haloperidol were shown to have increased brain drug concentration and prolonged haloperidol-induced latency, but no other phenotypes were reported^[32].

In human reticular dermis, ABCB5 was also shown to mark a cell subpopulation called dermal immunomodulatory mesenchymal cells, which co-expressed CD29, CD44, CD49e, CD73, CD105, and CD166 stem cell markers^[33]. This cell subpopulation preferentially expressed programmed cell death protein 1 (PD-1) and was able to modulate primary immune responses in mice after syngeneic or allogeneic *in vivo* injection^[33]. In a murine heterotopic cardiac allograft model, allogeneic transplantation of ABCB5⁺

dermal immunomodulatory mesenchymal cells increased allograft survival^[33]. The knockdown of PD-1 in this cell subpopulation attenuated the prolongation of cardiac allograft survival, suggesting that the immunoregulatory function of ABCB5⁺ cells is mediated in part by PD-1 expression^[33]. ABCB5⁺ dermal immunomodulatory mesenchymal cells have been shown to secrete interleukin-1 receptor antagonist (IL-1RA), which induces a shift from pro-inflammatory M1 macrophages to tissue-healing M2 macrophages^[34]. Recently, these dermal immunomodulatory mesenchymal cells have been used to enhance tissue repair in patients with chronic venous ulcers refractory to compression therapy^[35,36].

Cancer stem cells

Cancer stem cells (CSCs) are defined as a subpopulation of cells within tumors that are capable of self-renewal, differentiation, and tumorigenicity. These cells have been shown to express ABC transporters, which may explain why CSCs are resistant to chemotherapeutic agents. Recently, it has been proposed that ABC transporters may also be involved in the efflux of molecules (e.g., hormones, signaling molecules, nutrients, metabolites) that are important for intercellular communication or the extracellular environment of CSCs^[37].

ABCB5 β has been identified as a marker of CSCs in various cancers [Table 3]. However, most experiments in the literature only show the co-expression of several CSC markers with ABCB5, without demonstrating that this enriched ABCB5⁺ cell population has CSC properties. Furthermore, several experiments were performed with antibodies whose specificity was questioned in Table 2.

In addition to the cancer types shown in Table 3, ABCB5 has also been shown to mark a CSC population in melanoma. Interestingly, most of the literature investigating the role of ABCB5 as a marker of CSC has focused on this cancer type. First, Frank *et al.* showed that enriched CD133⁺ G3361 cell subpopulation had increased ABCB5 expression^[2]. ABCB5 marked a distinct cell population from CD133⁺ G3361 melanoma cells, consisting of mononucleated and multinucleated cells. In this experiment, ABCB5 expression was analyzed by flow cytometry using the 3C2-1D12 antibody which is not commercially available. Similarly, ABCB5 mRNA was increased in a human melanoma side population selected by Hoechst 33342 dye exclusion^[49]. Hoechst dye, which emits a greater amount of fluorescence when bound to DNA, is preferentially excluded from CSCs. In another publication, the number of CD133⁺ ABCB5⁺ cells was higher in advanced-stage human cutaneous melanoma compared to benign nevi^[50]. However, these data were obtained by immunohistochemistry and the anti-ABCB5 antibody used was not mentioned. Interestingly, by flow cytometry using the 3C2-1D12 antibody, most of the purified CD133⁺ melanoma tumor cells were shown to express ABCB5, and the purified CD133⁺/ABCB5⁺ cells were able to regenerate a heterogeneous tumor in *in vitro* culture^[18]. ABCB5 and CD133 were also co-expressed in clinical melanoma samples using immunofluorescence and 3C2-1D12 antibody^[18]. Schatton *et al.* showed that human ABCB5⁺ melanoma cells were able to restore tumor heterogeneity compared to ABCB5⁻ cells when using primary patient-derived tumor cells in human to NOD/SCID mouse xenotransplantation^[51]. ABCB5⁺ cells were purified using immunomagnetic selection and 3C2-1D12 antibody. Furthermore, in the same publication, ABCB5⁺ cells showed greater tumorigenicity in the G3361 NOD/SCID mouse xenograft model analyzed for 6 weeks^[51]. ABCB5⁺ melanoma cells purified by immunomagnetic selection and 3C2-1D12 antibody had immunomodulatory functions including inhibition of IL-2 secretion and induction of IL-10 secretion, which affected antitumor immunity by inhibiting T-cell activation^[52]. In addition, they presented other features involved in immune escape, including decreased major histocompatibility complex type 1 expression and preferential expression of PD-1 and B7.2, two immunotherapy targets. Wilson *et al.* highlighted that in the ABCB5⁺ melanoma cell subpopulation purified by immunomagnetic selection and 3C2-1D12 antibody, ABCB5 is involved in WFDC1 repression (a repressor of the WNT signaling pathway) and IL-1 β secretion, which maintains aggressiveness and communication with ABCB5⁻ tumor cells through

Table 3. Cancer types in which ABCB5 was identified as a marker of CSCs

Type of cancer	Evidence supporting ABCB5 as a marker of CSC	Ref.
Breast cancer	ABCB5 co-expressed with CD133, NANOG, SOX2, and SORT1 in TNBC cells as detected by Western blotting using the antibody 140667 from Abcam	[38]
Colon cancer	CD133 ⁺ HT-29 cells have increased expression of ABCB5. However, data are not shown and the methodology for this experiment is missing	[39]
	ABCB5 co-expressed with CD133 by immunofluorescence using the antibody 3C2-1D12 which is not commercially available	[40]
Glioblastoma	ABCB5 co-expressed with CD133 in U-87, LN-18 and LN-229 primary tumor cell lines by flow cytometry using antibody 3C2-1D12 which is not commercially available	[41]
Hepatocellular carcinoma	ABCB5 co-expressed with CD133 in hepatocellular carcinoma patient samples by flow cytometry using antibody EB08211 from Everest Biotech Ltd antibody	[42]
	ABCB5 co-expressed with CD133 in Hep3B xenografts by flow cytometry using antibody 600-401-A77 from Rockland	[43]
	Tumorigenicity of purified ABCB5 ⁺ Hep3B cells by flow cytometry using antibody 600-401-A77 from Rockland and EB08211 from Everest Biotech Ltd antibody was assessed by colony formation assay and injection into BALB/c nude mice. ABCB5 ⁺ cells had a greater number of colonies compared to ABCB5 ⁻ cells and mice injected with ABCB5 ⁺ cells formed tumors in 2 to 4 weeks compared to ABCB5 ⁻ (12 weeks) and the cell population was heterogeneous	[44]
Mesothelioma	Mesothelioma-initiating cells were selected from human primary samples by culturing the cells in HAM F12/DMEM medium supplemented with 1% PS, 20 ng/mL of EGF, 20 ng/mL of β -FGF, 4 μ g/mL of IGF, 0.2% v/v B27, followed by selection by flow cytometry based on Oct4, Nanog, SOX2 and ABCG2 expression. In this subpopulation, ABCB5 expression (mRNA and protein using antibody SAB1300315 from Sigma) was increased	[45]
Oral squamous cell carcinoma	ABCB5 co-expressed with CD44 by immunofluorescence using Hpa026975 antibody from Atlas Antibodies in BICR3 and BICR56 cells	[46]
Osteosarcoma	CSCs of OS-65 cells were distinguished by flow cytometry using Hoechst 33342 dye exclusion. In this SOX2, OCT-4 and NANOG positive cells (confirmed by RT-qPCR and immunofluorescence), ABCB5 mRNA was upregulated by RT-qPCR	[47]
Retinoblastoma	CD133 ⁺ Y79 cells have an increased expression of ABCB5 mRNA in RT-qPCR compared to CD133 ⁻ Y79 cells	[48]

Experiments performed to identify ABCB5 as a marker of CSCs are listed as well as the antibody that was used. CSC: Cancer stem cell; TNBC: triple-negative breast cancer; PS: penicillin-streptomycin; EGF: epidermal growth factor; β -FGF: basic fibroblast growth factor; IGF: insulin-like growth factor.

IL-1 β /IL-8/CXCR1 signaling^[53]. Similarly, the Wnt/IL-1 β /IL-8 pathway was shown to induce ABCB5 expression in mesothelioma, and three signaling pathways, NF- κ B, α 6- β 4-integrin, and IL-1, were overexpressed in ABCB5⁺ melanoma cells purified by immunomagnetic selection and abcam 140667 anti-ABCB5 antibody^[54]. ABCB5 has been shown to activate the NF- κ B pathway by inhibiting p65 ubiquitination, thereby increasing its stability.

In contrast, Quintana *et al.* did not observe a correlation between the expression of ABCB5 and 18 other CSC markers using the 3C-1D12 antibody^[55]. Furthermore, ABCB5⁺ and ABCB5⁻ cells purified by flow cytometry using 3C-1D12 antibody had similar tumorigenic capacities and were able to restore tumor heterogeneity in mouse xenograft models transplanted with Matrigel^[55]. In melanoma or retinoblastoma cell culture, ABCB5 protein (600-401-A77 antibody from Rockland) or mRNA expression did not correlate with CD271 or CD133 expression^[48,56]. Consequently, Quintana *et al.* challenged the model of CSCs in melanoma and instead proposed that melanoma is not organized hierarchically, but that each cell undergoes reversible phenotypic changes; this model is called “phenotype switching”. Consistent with this, Louphrasitthiphol *et al.*, using the TGCA database and the Cancer Cell Line Encyclopedia (CCLE) database, showed that ABCB5 mRNA was associated with MITF mRNA expression, a marker of proliferative/differentiated melanoma cells^[25]. On the other hand, no correlation was found with AXL, a marker of stemness, suggesting that ABCB5 expression is not exclusive to an undifferentiated stem cell population but rather that this transporter is expressed in differentiated melanoma cells. For a long time, the existence of melanoma cancer stem cells has remained controversial in the literature, and two different models have been proposed, either every cell in a tumor can become tumorigenic due to clonal selection or mutations, or only a subpopulation

of cells is tumorigenic, the CSCs^[57]. Part of the controversy stems from different interpretations of the CSCs concept. CSCs and stem cells share similar characteristics, but they are not further related, and cancer stem cells do not necessarily arise from normal stem cells^[57,58]. Furthermore, as reviewed by Girouard *et al.*, the criteria and methods used to identify and characterize CSCs vary widely in the literature^[57]. For example, the use of Matrigel may increase tumor formation^[57]. Although the literature is still controversial regarding the existence of CSCs in melanoma, the “phenotype switching” model is the most commonly used to explain tumorigenesis in recent publications on melanoma formation and progression, which calls into question the expression of ABCB5 in CSCs^[59,60]. It is important to note that the majority of the literature supporting the role of ABCB5 in CSCs is dominated by the use of the 3C2-1D12 antibody, and when a different antibody is used (in this case 600-401-A77 from Rockland), opposite results are obtained. Further confirmation regarding antibody specificity is needed to disentangle the role played by ABCB5 in CSCs. Moreover, if ABCB5 expression in CSCs happens to be validated, it will be necessary to determine if this transporter is implicated in MDR in this cell type or has another function.

Further, all published data on ABCB5 expression in melanoma CSCs rely on antibodies to isolate ABCB5⁺ cells. These antibodies can recognize at least the two longest isoforms. A similar issue is seen with the probes used to correlate ABCB5 mRNA expression with various CSC markers. Nevertheless, two publications performed side experiments in which ABCB5 β can be distinguished, suggesting that ABCB5 β is the isoform that is preferentially expressed in melanoma^[2,18]. A simple confirmation would be to analyze ABCB5FL and ABCB5 β mRNA expression in this cell subpopulation using specific probes.

ABCB5 IN CANCER BIOLOGY AND MULTIDRUG RESISTANCE

High ABCB5 expression has been reported in several malignancies. Using immunofluorescence and MABC711MI antibody from ThermoFisher Scientific, Saeed *et al.* detected ABCB5 expression in various tumors derived from the following tissues (prostate, pancreas, brain, kidney, liver, stomach, ovary, esophagus, pharynx, bladder, and thyroid)^[13]. ABCB5 expression was the highest in carcinomas of the prostate, pancreas, breast, lung, kidney, liver, and stomach, while the others showed a high interindividual variation of ABCB5 expression. Table 4 highlights the publications in which ABCB5 expression was detected in patient tumor samples^[61-78]. As shown in Table 4, most of the published data are based on experiments performed exclusively with antibodies and probes. For ABCB5 mRNA expression, the probes always recognize both longest isoforms of ABCB5. A similar problem exists with the antibodies used. Since the probes and antibodies do not distinguish between ABCB5FL and ABCB5 β , it is difficult to determine which isoform is predominantly expressed in these cancers. However, based on the expression of ABCB5 β in healthy tissues, we can hypothesize that these publications refer to the same isoform. Table 4 only recapitulates the tissue expression of ABCB5, but this transporter was also detected in several cell lines derived from the mentioned tissues. It is interesting to note that most of the melanoma cell lines used in the NCI-60 panel, a group of 60 cancer cell lines used for drug screening, express ABCB5^[3,79,80].

Cancer biology

In conjunction with its role as a marker of CSCs, ABCB5 has been associated with cancer progression in several cancer types. Studies have shown (1) a correlation of ABCB5 expression with tumor stage *in vitro* and *in vivo*; (2) a correlation of ABCB5 expression with tumor stage in cancer patient tissues; (3) a correlation of ABCB5 expression with patient survival and tumor progression; and (4) direct *in vitro* and *in vivo* evidence.

(1) ABCB5 expression *in vitro* and *in vivo* was correlated with tumor stage and aggressiveness. Using Western blotting, without specifying the antibody used, and RT-qPCR, it was shown that non-invasive

Table 4. Cancers in which ABCB5 expression has been identified outside of its role as a marker of CSC

Type of cancer	Technique used	Ref.
Breast cancer	RT-qPCR	[61]
	Next-generation sequencing, whole genome sequencing	[62]
Colorectal cancer	Immunohistochemistry using 3C2-1D12 antibody, which is not commercially available	[40]
Hematological malignancies	RT-qPCR	[63]
	RT-qPCR	[64]
	RT-qPCR	[65]
Hepatocellular carcinoma	PCR DNA sequencing	[66]
	RT-qPCR	[67]
	RT-qPCR	[68]
Lung cancer	Next-generation sequencing, whole genome and transcriptome sequencing	[69]
	Next-generation sequencing, whole exome sequencing	[70]
Melanoma	Immunohistochemistry but no information on the antibody used	[71]
	RT-qPCR	[72]
	Immunohistochemistry using antibody ab140667 from Abcam	[73]
	Immunohistochemistry using antibody NBP1-77687 from Novus Biological	[74]
Merkel cell carcinoma	Immunohistochemistry using 3C2-1D12 antibody, which is not commercially available	[75]
Ocular surface squamous neoplasia	Immunohistochemistry using antibody NBP1-50547×500 from Novus Biological	[22]
Oral squamous cell carcinoma	Immunohistochemistry using antibody Hpa026975 from Atlas Antibodies	[76]
	Immunohistochemistry using antibody Hpa026975 from Atlas Antibodies and RT-qPCR	[46]
Pancreatic cancer	RT-qPCR	[77]
Papillary thyroid carcinoma	Immunohistochemistry using antibody GTX60661 from GeneTex	[78]

This table recapitulates the techniques used to identify ABCB5 expression in patient tumors. CSC: Cancer stem cell; RT-qPCR: reverse transcription quantitative polymerase chain reaction.

breast cancer cell lines (MDA-MB-468 and MCF7) had decreased expression of ABCB5 compared to an invasive cell line (BT549)^[61]. Similarly, ABCB5 mRNA was six times less expressed in WM-115, derived from a primary melanoma tumor, compared to WM-266-4, derived from metastasis from the same patient^[20]. In an orthotopic mouse model of conjunctival melanoma, ABCB5 expression, analyzed by flow cytometry using the 3C2-1D12 antibody which is not commercially available, increased during tumor expansion phases and its expression was higher in metastasis^[81].

(2) ABCB5 expression has been shown to be higher in more advanced stages of cancer, metastasis, and refractory tumors when examined by immunohistochemistry or RT-qPCR in patients with colorectal cancer, oral squamous cell carcinoma, leukemia, and breast cancer^[40,46,61,63]. In immunohistochemistry, ABCB5 expression gradually increases from benign nevus to invasive melanoma and from normal oral mucosal tissue to oral precancerous lesions and squamous intraepithelial neoplasia^[71,73,76]. Transcriptomic data from different datasets showed that ABCB5 is overexpressed in alveolar soft-part sarcoma^[82]. ABCB5 expression was increased in ocular surface squamous cell carcinoma compared to normal limbal tissue by immunohistochemistry^[22]. Furthermore, its expression was no longer restricted to the basal epithelial layer but reached suprabasal and superficial cells in tumor tissue. However, tumor recurrence in ocular surface squamous cell carcinoma after treatment is rare, and when it does occur, re-administration of the same anticancer agent is often effective^[22]. Because of the ABCB5 expression pattern in tumors of cancer patients and because multidrug resistance is rarely seen in ocular surface squamous neoplasia where ABCB5 is overexpressed, the hypothesis that ABCB5 may be involved in tumor progression is strengthened.

(3) ABCB5 expression has been shown to correlate with overall survival and/or tumor progression in several cancer types, as summarized in Table 5^[83-86]. RT-qPCR identified ABCB5 as a marker of circulating melanoma cells in the peripheral blood of patients and its expression correlated with disease progression and recurrence^[86,87]. ABCB5 mRNA was upregulated in the peripheral blood of colorectal cancer patients and its expression correlated with cancer progression^[84]. Similarly, ABCB5 mRNA in the bone marrow of colorectal cancer patients was negatively associated with tumor progression and overall survival^[83]. Grimm *et al.* showed that ABCB5 expression, analyzed by immunohistochemistry, was associated with tumor progression and recurrence in patients with oral squamous cell carcinoma^[46]. Other studies have shown that ABCB5 expression, by immunochemistry, is associated with tumor thickness, a prognostic factor for patient survival^[74,78]. Whole genome sequencing has shown that various single nucleotide polymorphisms (SNPs), i.e., single nucleotide variations in the DNA sequence that occur in more than 1% of the population, of ABCB5 were associated with cancer occurrence in sarcoma and hepatocellular carcinoma (rs2074000, rs58795451, rs751879475, rs73684574, rs78879263, rs78155891, rs75494098, rs4721940, rs10254317)^[66,88]. In hepatocellular carcinoma, SNPs were also associated with tumor size (rs73076550, rs75494098, rs76859629, rs12669250), tumor stage (rs2106562, rs17143187, rs17143212, rs2074000, rs10254317), and disease-free survival (rs2893006, rs34603556, ss836312078, rs79998607, ss1148219560, rs111872870, rs75494098, rs76859629, rs11769236, rs11772926, ss836312077 and ss836312079)^[66]. Using data from two gene expression databases, The Cancer Genome Atlas Program (TCGA) and Gene Expression Omnibus (GEO), Shang *et al.* showed that ABCB5 expression in gastric cancer was associated with increased metastasis and worse overall survival^[85]. Furthermore, sequencing showed that SNPs of ABCB5 were associated with decreased melanoma risk (i.e., rs10231520, rs17817117, and rs2301641)^[89]. The rs2301641 SNP encodes a nonsynonymous mutation, K115E, which is associated with lower melanoma risk and reduced ABCB5 β transport capacity. In addition, a missense substitution in the melanocyte-inducing transcription factor (MITF), E318K, has been associated with a predisposition to melanoma and renal cell carcinoma^[90]. MITF has previously been shown to bind to the ABCB5 promoter region and regulate its expression^[25]. ABCB5-mediated transcription by MITF was induced by β -catenin^[25]. The E318K mutation increases the binding of MITF to the ABCB5 locus, resulting in the upregulation of ABCB5^[90]. In the same theme, several transcription factors have been shown to influence ABCB5 expression. The proto-oncogene c-Myc binds to the ABCB5 promoter region and increases its expression^[39,91]. The p73 isoform Δ Np73, a member of the p53 family, was able to regulate ABCB5 expression in breast cancer cells^[92]. In addition, several microRNAs (miRNAs) were shown to decrease ABCB5 expression. miRNAs are single-stranded non-coding RNA that prevent mRNA translation into protein. miR-4282 and miR-522 were shown to bind to the ABCB5 sequence in pancreatic and colon cancer cell lines, respectively, using luciferase assays^[77,93]. Overexpression of these miRNAs negatively affected either the resistance of cancer cells or their ability to migrate. Taken together, they represent a promising tool for cancer research and targeting of ABCB5. Nevertheless, further investigations are needed to better characterize the mechanisms and underlying effect of these miRNAs in colon and pancreatic cancer, but also in other malignancies.

(4) It is important to emphasize that the experiments mentioned in (1), (2), and (3) provide only correlation data. To accurately interpret these findings, they must be supported by experimental evidence including downregulation and overexpression experiments. For instance, Yao *et al.* showed that decreased ABCB5 expression after shRNA reduced cell migration and invasion in Transwell migration and Matrigel invasion assays in a breast cancer cell line^[61]. In addition, shRNA against ABCB5 in these cells resulted in fewer metastases after tail vein injection of mice. On the other hand, overexpression of ABCB5 β resulted in increased migration and invasion *in vitro* and metastasis *in vivo*^[61]. siRNA against the zinc finger E-Box binding homeobox 1 (ZEB1) oncogene had similar results to ABCB5 knockdown^[61]. The authors suggested that ZEB1 expression is regulated by ABCB5, but the published data using luciferase assay and qChIP assay suggest that ABCB5 acts as a transcription factor and binds to the ZEB1 promoter region to regulate its

Table 5. Association between ABCB5 expression in patients' tumor and clinical outcome

Tumor	ABCB5 expression	Clinical outcomes	Ref.
Colorectal adenocarcinoma	RT-qPCR on ABCB5 mRNA in patient bone marrow	→ Increased tumor progression → Increased tumor recurrence → Decreased overall survival	[83]
Colorectal adenocarcinoma	RT-qPCR on ABCB5 mRNA in circulating tumor cells of peripheral blood from patients	→ Increased tumor progression → Decreased overall survival	[84]
Gastric cancer	ABCB5 mRNA from TCGA and GEO database	→ Poor prognosis	[85]
Melanoma	RT-qPCR on ABCB5 mRNA in circulating tumor cells of peripheral blood from patients	→ Increased tumor recurrence	[86]
Oral squamous cell carcinoma	Immunohistochemistry of ABCB5 expression in tumor samples	→ Increased tumor recurrence → Increased tumor progression	[46]
Papillary thyroid cancer	Immunohistochemistry of ABCB5 expression in tumor samples	→ Increased tumor size	[78]

Patients' tumors where ABCB5 expression has been associated with clinical outcomes are presented. GEO: Gene Expression Omnibus.

expression, an unconventional function for a transmembrane protein. In a xenograft mouse model or *in vitro* culture of colorectal cancer cells, ABCB5 was shown to promote invasion and epithelial-to-mesenchymal transition (EMT)^[84]. Invasion and EMT were mediated by IL-8 induction of the oncogene receptor tyrosine kinase AXL and were dependent on ABCB5 expression^[84]. All these experimental data suggest that ABCB5 functions as an oncogene. Conversely, Govindan *et al.* detected three nonsynonymous mutations by sequencing in 17 patients with non-small cell lung cancer^[69]. In various cancers, 134 missense mutations and 20 truncating mutations were detected in ABCB5^[94]. Furthermore, Sana *et al.* showed that ABCB5FL was mutated in 13.75% of the 640 human melanoma samples tested^[95]. ATPase assays showed that these mutations resulted in decreased ATP hydrolysis and increased proliferation, migration, and invasion. The effects were greater in the melanoma cell lines carrying the NRAS activating mutation, Q16K, except for invasion capacity, which was only seen in cell lines carrying the BRAF activating mutation, V600E^[95]. To validate these data, the authors used a shRNA targeting ABCB5 in A375 and SK-Mel-28. Downregulation of ABCB5 resulted in increased proliferation of SK-Mel-28, and larger colonies for both cell lines in an anchorage-independent soft agar assay^[95]. Since ABCB5 β is the isoform constitutively expressed in these cell types, the identified phenotype cannot be attributed to the downregulation of ABCB5FL, but rather to the decreased expression of ABCB5 β . However, it suggests that ABCB5 β functions as a tumor suppressor in the opposite direction to the data presented above. The conflicting results observed may be because the two longest isoforms may have opposite functions in cancer biology. To date, data suggest that ABCB5FL acts as a tumor suppressor while ABCB5 β is an oncogene. However, the existence of conflicting results on the same isoform raises questions and further experiments are needed to better determine the implication of each isoform in cancer biology. Additionally, we must keep in mind that shRNA experiments have limitations including off-target effects and limited efficacy. In both publications using shRNA, the downregulation of ABCB5 is confirmed by looking at its mRNA expression and/or protein level using an antibody that was shown to lack specificity^[61,95]. Moreover, since antibodies do not allow to distinguish between these two proteins, experiments need to be properly designed and the addition of a rescue experiment with transfection of ABCB5 β and ABCB5FL sequences separately might help to better identify the transporter responsible for the observed phenotype.

Multidrug resistance

ABCB1 has been extensively studied for its role in multidrug resistance through the efflux of chemotherapeutic drugs from cancer cells, leading to treatment failure. Due to their high homology, ABCB5 was expected to have a similar function, and this has been reported in several publications. Regarding the involvement of ABCB5 in cancer biology, different types of evidence can be found in the literature: (1) correlation of ABCB5 expression and treatment with anticancer agents; (2) sensitization of cancer cell lines after siRNA or shRNA targeting ABCB5; (3) experimental data studying each isoform separately. Data showing an implication for ABCB5 in the transport of anticancer agents are summarized in [Table 6](#) and divided into direct and indirect evidence of transport.

(1) ABCB5 mRNA was increased in MCF-7 and K562 cells selected with doxorubicin or vinblastine, respectively^[98,101]. Treatment with 5 μ M doxorubicin resulted in increased ABCB5 mRNA expression in three melanoma cell lines (i.e., A375, 1205Lu, and DMBC8)^[99]. Selection of MKL-1, MKL-2, MS-1, and WaGa cells with carboplatin and etoposide resulted in increased expression of ABCB5 mRNA^[75]. Patients with resistant acute myeloid leukemia, breast cancer, and Merkel cell carcinoma had increased expression of ABCB5 mRNA after standard treatment with chemotherapeutic agents^[64,75,96]. Similarly, patients with melanoma treated with dacarbazine had increased ABCB5 mRNA expression, and treatment with dacarbazine *in vitro* resulted in the selection of ABCB5-expressing cells^[20]. Colorectal cancer patients treated with 5-FU had increased ABCB5 expression on immunohistochemistry compared to the same tissue before treatment^[40]. In breast cancer patients, the ABCB5 SNP rs3210441 was associated with response to neoadjuvant cytotoxic therapy and ABCB5 expression in TCGA was associated with anthracycline resistance^[62,96]. In a murine xenograft model of melanoma, temozolomide led to the selection of ABCB5-expressing cells^[20]. In addition, *abcb5* overexpression in zebrafish reduced mercury toxicity, and in mice, *abcb5* expression at the blood-brain barrier was shown to influence brain levels of haloperidol^[32,102]. Notably, ABCB5 expression at mRNA and protein levels was increased in cell lines resistant to vemurafenib, a molecule targeting the BRAF-activating mutation V600E used in the treatment of melanoma^[100]. However, ABCB5 was not responsible for resistance to vemurafenib.

(2) Once again, it is important to emphasize that the experiments mentioned in (1) only provide correlation data. To interpret these findings correctly, they must be supported by additional experimental evidence, such as downregulation and overexpression studies. For instance, siRNA against ABCB5 has been shown to sensitize Sk-Mel 28 cells to camptothecin and 5-FU^[97]. Similarly, shRNA targeting ABCB5 inhibited cancer growth and sensitized cells to 5-FU in a colorectal cancer xenograft^[40]. Blockade of ABCB5 with an anti-ABCB5 mAb reduced cancer growth in a Merkel cell carcinoma xenograft^[75]. G3361 melanoma cells expressing ABCB5 accumulated less doxorubicin and blockade of ABCB5 with the same anti-ABCB5 mAb increased doxorubicin uptake^[18]. However, both studies use an anti-ABCB5 mAb (3C2-1D12) for which there is no experimental evidence of ABCB5 inhibition. The antibody recognizes amino acids in one of the extracellular loops of ABCB5, on the opposite side of the membrane from the NDBs. Therefore, the inhibition of this transporter is not mediated by ATP hydrolysis blocking. Furthermore, there is no evidence that this antibody interferes with substrate binding and both publications do not confirm the results obtained with ABCB5 downregulation using shRNA. Nevertheless, further experiments in the literature confirmed their results using ABCB5 downregulation. Liver cancer cells overexpressing ABCB5 had decreased uptake of doxorubicin and siRNA against ABCB5 sensitized cells to doxorubicin^[68]. shRNA against ABCB5 or anti-ABCB5 mAb on G3361 melanoma cells decreased cancer cell survival to dacarbazine, paclitaxel, teniposide, docetaxel, etoposide, doxorubicin, and vincristine^[53]. Similarly, blockade of ABCB5 with anti-ABCB5 mAb or downregulation with shRNA resulted in decreased proliferation of glioblastoma multiforme and sensitized cells to temozolomide in both cell culture and xenograft models^[41]. In addition, ABCB5 was shown to mediate resistance to caffeic acid phenethyl ester, a bioactive molecule

Table 6. List of anticancer agents to which ABCB5 has been proposed to mediate resistance

Anticancer agent	Direct evidence that ABCB5 transports anticancer agent	Indirect evidence that ABCB5 transports anticancer agent
Adriamycin		Increased ABCB5 mRNA after Adriamycin treatment in breast cancer patients ^[96]
Camptothecin	siRNA against ABCB5 resensitized SK-Mel 28 to camptothecin ^[97]	
Carboplatin		Increased ABCB5 mRNA after selection with carboplatin of MKL-1, MKL-2, MS-1, and WaGa cells ^[75] Increased ABCB5 mRNA after treatment with carboplatin in patients with Merkel cell carcinoma ^[75]
Dacarbazine	shRNA against ABCB5 or anti-ABCB5 mAb blockade of ABCB5 on G3361 melanoma cells resulted in decreased survival ^[53]	Increased ABCB5 mRNA after dacarbazine treatment in melanoma patients ^[20] Treatment of WM-266-4 cells with dacarbazine results in selection of ABCB5-expressing cells ^[20]
Docetaxel	shRNA against ABCB5 or anti-ABCB5 mAb blockade of ABCB5 on G3361 melanoma cells resulted in decreased survival ^[53] HEK-293 transfected with ABCB5FL were more resistant to docetaxel and showed decreased uptake of this anticancer agent ^[6] Stimulation of ABCB5FL ATPase activity in the presence of docetaxel ^[6]	
Doxorubicin	shRNA against ABCB5 or anti-ABCB5 mAb blockade of ABCB5 on G3361 melanoma cells resulted in decreased survival ^[53] G3361 melanoma cells expressing ABCB5 accumulate less doxorubicin ^[75] Anti-ABCB5 mAb blockade of ABCB5 on G3361 melanoma cells increases doxorubicin uptake ^[75] Liver cancer cells overexpressing ABCB5 have a decreased doxorubicin uptake ^[68] siRNA against ABCB5 sensitized liver cancer cells to doxorubicin ^[68]	Increased ABCB5 mRNA after doxorubicin selection of MCF-7 cell ^[98] Increased ABCB5 mRNA after doxorubicin treatment of A375, 1205Lu, and DMBC8 ^[99] Increased ABCB5 mRNA after treatment with doxorubicin in breast cancer patients ^[96]
Epirubicin		Increased ABCB5 mRNA after treatment with epirubicin in breast cancer patients ^[96]
Etoposide	shRNA against ABCB5 or anti-ABCB5 mAb blockade of ABCB5 on G3361 melanoma cells resulted in decreased survival ^[53]	Increased ABCB5 mRNA after etoposide selection of MKL-1, MKL-2, MS-1, and WaGa cells ^[75] Increased ABCB5 mRNA after treatment with carboplatin in patients with Merkel cell carcinoma ^[75]
Paclitaxel	shRNA against ABCB5 or anti-ABCB5 mAb blockade of ABCB5 on G3361 melanoma cells resulted in decreased survival ^[53] HEK-293 transfected with ABCB5FL were more resistant to paclitaxel and showed decreased uptake of this anticancer agent ^[6]	
Temozolomide	shRNA against ABCB5 or anti-ABCB5 mAb blockade of ABCB5 resulted in decreased proliferation of glioblastoma multiforme and sensitized cells to temozolomide in both cell culture and xenograft models ^[41]	Treatment of xenografts in mice with temozolomide resulted in the selection of ABCB5-expressing cells ^[20]
Teniposide	shRNA against ABCB5 or anti-ABCB5 mAb blockade of ABCB5 on G3361 melanoma cells resulted in decreased survival ^[53]	
Vemurafenib		Treatment of WM-266-4 cells with vemurafenib resulted in the selection of ABCB5-expressing cells ^[20] Increased ABCB5 mRNA and protein expression in cell lines resistant to vemurafenib ^[100]
Vinblastine		Increased ABCB5 mRNA after vinblastine selection of K562 cells ^[101]
Vincristine	shRNA against ABCB5 or anti-ABCB5 mAb blockade of ABCB5 in G3361 melanoma cells resulted in decreased survival ^[53]	
5-FU	siRNA against ABCB5 resensitized SK-Mel 28 to 5-FU ^[97] ShRNA against ABCB5 resensitized colorectal cancer xenografts to 5-FU ^[40]	Treatment of colorectal cancer patients with 5-FU increased ABCB5 protein expression in their tumors ^[40]

10-OH
camptothecin

SiRNA against ABCB5 resensitized SK-Mel 28 to 10-OH camptothecin^[97]

Anticancer agents and the experiments suggesting ABCB5 transport of these drugs are presented in this table. The experiments are divided into two categories: (1) direct evidence and (2) indirect evidence.

with antitumor activity, in melanoma^[103]. However, as mentioned above, we must keep in mind that siRNA and shRNA experiments have limitations including off-target effects and limited efficacy. Further, several publications lack proper proof of validation of ABCB5 downregulation in addition to using antibodies not validated in the literature^[40,53].

(3) In contrast to other publications that did not study a specific isoform, Keniya *et al.* decided to study the role of both isoforms separately in chemoresistance^[15]. In a yeast model, *Saccharomyces cerevisiae*, overexpression of ABCB5FL and ABCB1 mediated resistance to rhodamine 123 whereas ABCB5 β did not^[15]. Conversely, Frank *et al.* showed that ABCB5 β was able to transport rhodamine 123 in transfected MCF-7 cells^[2]. This could be explained by the fact that yeast lacks some human post-translational modifications and/or ABCB5 β interacting partners that could affect ABCB5 β transporter function, leading to opposite results in the two tested models. Nevertheless, Kawanobe *et al.* reported that HEK-293 cells overexpressing ABCB5FL were 1.5-fold more resistant to doxorubicin, 2.3-fold more resistant to paclitaxel, 3.0-fold more resistant to docetaxel, and 1.2-fold to 1.5-fold more resistant to daunorubicin, vincristine, etoposide, and actinomycin D than the parental HEK-293 cell line^[6]. These results were obtained in two different clones with the highest ABCB5FL expression out of seventeen and no resistance was observed in the mixed population of clones.

The fold change obtained for doxorubicin, daunorubicin, vincristine, etoposide, and actinomycin D is low and this experiment could have benefited from other validation. Regarding docetaxel and paclitaxel, HEK-293 cells overexpressing ABCB5FL had decreased uptake of radiolabeled drug. Resistance to methotrexate and 5-fluorouracil was not observed^[6]. In addition, when expressed in Sf21 insect cells, ABCB5FL and ABCB1 ATPase activity were 1.25-fold and 1.11-fold higher, respectively, in the presence of 100 μ M docetaxel^[6]. However, the observed fold change in ATPase activity is quite low and the concentration of docetaxel is particularly high compared to similar assays performed on other ABC transporters, which could affect membrane integrity. Overall, confirmations are needed to determine the implication of ABCB5FL in the transport of anticancer agents. Notably, the only difference between the two isoforms is the absence of the first TMD of ABCB5FL, the A-Loop, and Walker A in ABCB5 β . However, using molecular docking, Tangella *et al.* showed that the drug-binding pocket of several ABCB5 substrates (i.e., doxorubicin, daunorubicin, paclitaxel, vincristine, camptothecin, etoposide, docetaxel, and mitoxantrone) is located in the TMH present in TMD1 and TMD2 of ABCB5FL^[104]. Three potential binding sites were identified: site-1 (including residues in TMHs 1, 3, 4, 5, 6, 7, 8, 9, 10, 11, and 12), site-2 (including residues in TMHs 4, 5, 7, 8, 9 and 10), and site-3 (including residues in TMHs 2, 3, 6, 10 and 11). Therefore, ABCB5 β may not be able to transport these anticancer agents because this transporter lacks residues involved in substrate binding that are expressed in ABCB5FL. However, it is not excluded that both transporters transport chemotherapeutic agents. A larger number of compounds needs to be tested in different models to better distinguish which isoform is responsible for the observed multidrug resistance phenotype. Furthermore, the literature lacks transport assays in vesicles with radiolabeled or fluorescent drugs for these transporters. Interestingly, the putative binding sites discovered in ABCB5FL through molecular docking overlap with three binding sites found in human ABCB1 (i.e., prazosin-sites, H-sites and R-sites)^[104]. Therefore, ABCB5FL was hypothesized to have a substrate spectrum similar to ABCB1. However, in Sf21 insect cell membrane vesicles, ABCB5FL ATPase activity was not stimulated by verapamil, a known substrate of ABCB1 used to inhibit its transport

function^[6]. On the other hand, pretreatment of WM35 melanoma cells, expressing ABCB5 but not ABCB1, with verapamil resulted in increased intracellular concentration of doxorubicin, suggesting the inhibition of this transporter by verapamil^[105]. However, further experimental evidence is needed to confirm the inhibition and the impact on doxorubicin transport. Additionally, verapamil stimulated ATPase activity of Abcb5 in zebrafish and this stimulation was inhibited by tariquidar^[16]. Further, incubation of zebrafish with tariquidar led to a slight increase of Abcb5 mRNA, which was not significant^[106]. Overall, it is not clear whether ABCB1 inhibitors are also potent inhibitors of ABCB5 and transport assay with fluorescent or radiolabeled molecules will help identify ABCB5 inhibitors.

ABCB5 PHYSIOLOGICAL FUNCTION AND PATHOPHYSIOLOGY

So far, the physiological function of all ABCB5 isoforms remains unknown. Even though the literature lacks evidence that these proteins are physiologically relevant, phenotype changes seen after overexpression or knockout of ABCB5FL or ABCB5 β , respectively, have led to relevant hypotheses that must be further verified. HEK-293 cells overexpressing ABCB5FL were resistant to buthionine sulfoximine (BSO), an inhibitor of glutathione synthesis, resulting in increased glutathione levels^[107]. However, BSO uptake levels were similar in HEK-293 overexpressing ABCB5FL compared to the negative control. It was later discovered that HEK-293 cells overexpressing ABCB5FL also had increased levels of STAT1 and glutaminase, which were responsible for the observed resistance^[108]. However, STAT1 and glutaminase were not overexpressed or downregulated after transient transfection or siRNA targeting ABCB5; their increased expression was only detectable after stable transfection of this transporter. Therefore, metabolomic changes may occur after ABCB5FL overexpression that affect STAT1 expression over time. This hypothesis was confirmed by the analysis of the amino acid content of the ABCB5FL overexpressing HEK-293 cells and their WT counterparts. HEK-293 cells overexpressing ABCB5FL had increased cellular levels of glutamic acid, aspartic acid, and alanine, and decreased cellular levels of phenylalanine, tryptophan, leucine, isoleucine, glycine, methionine, valine, histidine, and tyrosine. Notably, STAT1 and glutaminase are involved in glutathione synthesis. The latter is an antioxidant involved in cellular detoxification and may be related to the CSC phenotype observed in cells overexpressing ABCB5. However, evidence to date suggests that ABCB5 β , and not ABCB5FL, is the isoform expressed in CSC. Since ABCB5FL localization is restricted to the testis and prostate, it has been proposed that it transports androgens^[6]. However, androgens did not affect the ATPase activity of ABCB5FL in ATPase assays^[6]. In zebrafish, expression of the ABCB5FL homolog, *abcb5*, was increased after bile salt injection, and activation of its transcription was associated with decreased bile acid in the liver, suggesting a role for this transporter in the regulation of bile salt secretion^[109,110]. Regarding ABCB5 β , Lutz *et al.* examined the metabolic profile of WT G3361, known to express ABCB5 β , or G3361 transfected with ABCB5 shRNA^[111]. After shRNA, cells had decreased levels of lactate, pyruvate, fumarate, alanine, glycerophosphoethanolamine, and glycerophosphocholine. A small redistribution in the phospholipid pool was also observed. These data suggest a role for ABCB5 β in glycolysis. Moreover, because ABCB5 β has been shown to mediate progenitor cell fusion, the authors hypothesized that this transporter may be involved in skin tissue turnover and renewal^[2].

In atherosclerosis, ABCB5 mRNA expression in microarray was increased in the plaques of high-risk patients compared to low-risk patients^[112]. Patients were divided into two groups (i.e., high and low risk) based on the ABCD2 prediction tool and CAR score. ABCB5 expression by immunohistochemistry was found in type II macrophages and lymphocytes in the vicinity of neovessels. Therefore, the authors proposed a potential function for ABCB5 in neovascularization^[112]. A multicenter genome-wide association study (GWAS) showed that ABCB5 SNPs were associated with neurological instability in ischemic stroke, and mouse brain microvascular endothelial cells deprived of oxygen for 3h to mimic cerebral ischemia had an increased number of exosomes, extracellular vesicles secreted by various cell types, expressing ABCB5

protein^[113,114]. ABCB5 SNPs were associated with changes in the PR interval, i.e., the interval between atrial depolarization and ventricular depolarization in the heartbeat, in another GWAS in the Brazilian population investigating potential genetic variation involved in the development of cardiomyopathy after *Trypanosoma cruzi* infection^[115]. In a GWAS investigating copy number variants (CNVs), ABCB5 deletion was associated with childhood obesity in African-American and European-American children^[116]. Whole blood RNA from American adolescents with attention-deficit hyperactivity disorder showed a 1.9-fold increase in ABCB5 mRNA^[117]. However, all these studies do not present direct evidence, but only correlations, and more research is needed to understand the role of ABCB5 in atherosclerosis, ischemic stroke outcome, cardiomyopathy, childhood obesity, and attention deficit hyperactivity disorder.

Next, Lin *et al.* showed that an ABCB5 SNP (rs2301641) was associated with increased melanin production and decreased transport capacity^[89]. Furthermore, in the immunohistochemistry of melanoma, cells expressing ABCB5 correlated with non-melanized regions^[51]. In contrast, ABCB5 expression was not detectable in two amelanotic melanoma cell lines^[3]. Taken together, this suggests a potential role for this transporter in melanogenesis.

In summary, most of the literature on ABCB5 has focused on its role as a marker of cancer stem cells and its implication in cancer biology and MDR. Few publications have investigated the physiological function of ABCB5FL and ABCB5 β . Preliminary data suggest that ABCB5FL is involved in cellular detoxification, while ABCB5 β seems to play a role in glycolysis and melanogenesis. However, the results obtained require further investigation and complementary experiments are needed to determine the pathway involved in the observed phenotypes following the knockdown or overexpression of these transporters separately.

No experimental data are available for the soluble isoforms of ABCB5. However, based on their structure, it has been hypothesized that they could function as regulators^[3]. Of note, ABCB5 α is the major isoform expressed in melanoma, and ABCB5.e has been cloned from mouse and human skin^[3,4].

CONCLUSION

In conclusion, a large amount of data on ABCB5 has been generated in recent years. Unfortunately, it remains difficult to disentangle the information proposed in the literature because it is difficult to distinguish between the different isoforms of ABCB5. To date, we know that ABCB5 encodes for several isoforms, two of which are transporters (i.e., ABCB5 β and ABCB5FL) and they have different promoters. ABCB5FL has the typical topology of full transporters and is localized in the testis and prostate. ABCB5 β has an atypical topology with a TMD flanked by two NBDs, one of which is truncated at the N-terminus and lacks the Walker A motif and the A-Loop. This transporter has a ubiquitous tissue expression and must homodimerize or heterodimerize to become functional. Both ABCB5 β homodimers and ABCB5 β /B6 or ABCB5 β /B9 heterodimers, identified in melanoma cells, were shown to have basal ATPase activity. Furthermore, ABCB5 β , first identified as a marker of skin progenitor cells, was shown to be expressed in a subpopulation of cells with stem cell-like properties in several tissues. This isoform was localized to the endoplasmic reticulum and its potential intracellular trafficking to other organelles requires further investigation. Regarding the involvement of ABCB5FL and ABCB5 β in tumorigenesis, a tumor suppressor and oncogene role, respectively, have been proposed. However, since there are conflicting results in the literature and because antibodies do not allow to distinguish between the two isoforms, we suggest adding a rescue experiment with the transfection of ABCB5 β and ABCB5FL sequences separately to better identify the transporter responsible for the observed phenotype. With regard to its role in MDR, ABCB5FL was shown to mediate resistance to docetaxel, doxorubicin, and paclitaxel. Other compounds have been proposed to be transported by the two isoforms, but there is no transport assay with separate expression of

each isoform to validate these hypotheses. To date, the literature lacks transport assays in vesicles with radiolabeled or fluorescent drugs to determine the extent of the involvement of ABCB5FL and ABCB5 β in MDR. Finally, the physiological function of these transporters (ABCB5 β , ABCB5 β /B6, ABCB5 β /B9, and ABCB5 FL) remains unknown and further research may help to better understand their role in normal cells. To this end, we suggest using omics techniques (metabolomics, proteomics, and transcriptomics) to further establish the consequence of ABCB5 isoform downregulation or overexpression in cell lines and animal models. Next, experiments looking at potential substrates, for example, could be performed. Overall, two important points need to be addressed in future publications on ABCB5 (1) to make sure of the isoform studied in a model that does not express both and (2) to validate the anti-ABCB5 antibodies in various applications. Such a strategy will help to generate reliable data to further elucidate the pathophysiological roles of ABCB5 transporters.

DECLARATIONS

Authors' contributions

Conceptualization and writing: Gerard L

Writing and supervision: Gillet JP

Availability of data and materials

Not applicable.

Financial support and sponsorship

This work is supported by the University of Namur.

Conflicts of interest

Gillet JP is an Editorial Board member of the journal *Cancer Drug Resistance*, while the other author has declared that there are no conflicts of interest.

Ethical approval and consent to participate

Not applicable.

Consent for publication

Not applicable.

Copyright

© The Author(s) 2024.

REFERENCES

1. Allikmets R, Gerrard B, Hutchinson A, Dean M. Characterization of the human ABC superfamily: isolation and mapping of 21 new genes using the expressed sequence tags database. *Hum Mol Genet* 1996;5:1649-55. DOI PubMed
2. Frank NY, Pendse SS, Lapchak PH, et al. Regulation of progenitor cell fusion by ABCB5 P-glycoprotein, a novel human ATP-binding cassette transporter. *J Biol Chem* 2003;278:47156-65. DOI PubMed
3. Chen KG, Szakács G, Annereau JP, et al. Principal expression of two mRNA isoforms (*ABCB 5 α* and *ABCB 5 β*) of the ATP-binding cassette transporter gene *ABCB5* in melanoma cells and melanocytes. *Pigment Cell Res* 2005;18:102-12. DOI PubMed PMC
4. Frank NY, Frank MH. ABCB5 gene amplification in human leukemia cells. *Leuk Res* 2009;33:1303-5. DOI PubMed PMC
5. Abcb5 ATP-binding cassette, sub-family B member 5 [*Mus musculus* (house mouse)]. Available from: <https://www.ncbi.nlm.nih.gov/gene/?term=AY766239> [Last accessed on 7 Aug 2024].
6. Kawanobe T, Kogure S, Nakamura S, et al. Expression of human ABCB5 confers resistance to taxanes and anthracyclines. *Biochem Biophys Res Commun* 2012;418:736-41. DOI PubMed
7. Thierry-Mieg D, Thierry-Mieg J. AceView: a comprehensive cDNA-supported gene and transcripts annotation. *Genome Biol* 2006;7:S12. DOI PubMed PMC
8. Severin J, Lizio M, Harshbarger J, et al; FANTOM Consortium. Interactive visualization and analysis of large-scale sequencing

- datasets using ZENBU. *Nat Biotechnol* 2014;32:217-9. DOI PubMed
9. Dobson L, Reményi I, Tusnády GE. The human transmembrane proteome. *Biol Direct* 2015;10:31. DOI PubMed PMC
 10. Baril SA, Gose T, Schuetz JD. How cryo-em has expanded our understanding of membrane transporters. *Drug Metab Dispos* 2023;51:904-22. DOI PubMed PMC
 11. Moitra K, Scally M, McGee K, Lancaster G, Gold B, Dean M. Molecular evolutionary analysis of ABCB5: the ancestral gene is a full transporter with potentially deleterious single nucleotide polymorphisms. *PLoS One* 2011;6:e16318. DOI PubMed PMC
 12. Gerard L, Duvivier L, Fourrez M, et al. Identification of two novel heterodimeric ABC transporters in melanoma: ABCB5 β /B6 and ABCB5 β /B9. *J Biol Chem* 2024;300:105594. DOI PubMed PMC
 13. Saeed MEM, Boulos JC, Machel K, et al. Expression of the stem cell marker ABCB5 in normal and tumor tissues. *In Vivo* 2022;36:1651-66. DOI PubMed PMC
 14. Fischer S, Klüver N, Burkhardt-Medicke K, et al. Abcb4 acts as multixenobiotic transporter and active barrier against chemical uptake in zebrafish (*Danio rerio*) embryos. *BMC Biol* 2013;11:69. DOI PubMed PMC
 15. Keniya MV, Holmes AR, Niimi M, et al. Drug resistance is conferred on the model yeast *Saccharomyces cerevisiae* by expression of full-length melanoma-associated human ATP-binding cassette transporter ABCB5. *Mol Pharm* 2014;11:3452-62. DOI PubMed PMC
 16. Robey RW, Robinson AN, Ali-Rahmani F, et al. Characterization and tissue localization of zebrafish homologs of the human ABCB1 multidrug transporter. *Sci Rep* 2021;11:24150. DOI PubMed PMC
 17. Ford RC, Marshall-Sabey D, Schuetz J. Linker domains: why ABC transporters “Live in Fragments no Longer”. *Trends Biochem Sci* 2020;45:137-48. DOI PubMed PMC
 18. Frank NY, Margaryan A, Huang Y, et al. ABCB5-mediated doxorubicin transport and chemoresistance in human malignant melanoma. *Cancer Res* 2005;65:4320-33. DOI PubMed
 19. Diaz-Anaya AM, Gerard L, Albert M, Gaussin JF, Boonen M, Gillet JP. The β isoform of human ATP-binding cassette B5 transporter, ABCB5 β , localizes to the endoplasmic reticulum. *Int J Mol Sci* 2023;24:15847. DOI PubMed PMC
 20. Chartrain M, Riond J, Stennevin A, et al. Melanoma chemotherapy leads to the selection of ABCB5-expressing cells. *PLoS One* 2012;7:e36762. DOI PubMed PMC
 21. Téllez J, Romero I, Soares MJ, Steindel M, Romanha AJ. Knockdown of host antioxidant defense genes enhances the effect of glucantime on intracellular *Leishmania braziliensis* in human macrophages. *Antimicrob Agents Chemother* 2017;61:e02099-16. DOI PubMed PMC
 22. Jongkhajornpong P, Nakamura T, Sotozono C, Nagata M, Inatomi T, Kinoshita S. Elevated expression of ABCB5 in ocular surface squamous neoplasia. *Sci Rep* 2016;6:20541. DOI PubMed PMC
 23. Volpicelli ER, Lezcano C, Zhan Q, et al. The multidrug-resistance transporter ABCB5 is expressed in human placenta. *Int J Gynecol Pathol* 2014;33:45-51. DOI PubMed PMC
 24. Ksander BR, Kolovou PE, Wilson BJ, et al. ABCB5 is a limbal stem cell gene required for corneal development and repair. *Nature* 2014;511:353-7. DOI PubMed PMC
 25. Louphasitthiphol P, Chauhan J, Goding CR. ABCB5 is activated by MITF and β -catenin and is associated with melanoma differentiation. *Pigment Cell Melanoma Res* 2020;33:112-8. DOI PubMed
 26. O’Gorman MR, Thomas J. Isotype controls - time to let go? *Cytometry* 1999;38:78-80. PubMed
 27. Edfors F, Hober A, Linderbäck K, et al. Enhanced validation of antibodies for research applications. *Nat Commun* 2018;9:4130. DOI PubMed PMC
 28. Uhlen M, Bandrowski A, Carr S, et al. A proposal for validation of antibodies. *Nat Methods* 2016;13:823-7. DOI PubMed PMC
 29. Kropf C, Fent K, Fischer S, Casanova A, Segner H. ABC transporters in gills of rainbow trout (*Oncorhynchus mykiss*). *J Exp Biol* 2020;223:jeb221069. DOI PubMed
 30. Vagin O, Kraut JA, Sachs G. Role of N-glycosylation in trafficking of apical membrane proteins in epithelia. *Am J Physiol Renal Physiol* 2009;296:F459-69. DOI PubMed PMC
 31. Norrick A, Esterlechner J, Niebergall-Roth E, et al. Process development and safety evaluation of ABCB5⁺ limbal stem cells as advanced-therapy medicinal product to treat limbal stem cell deficiency. *Stem Cell Res Ther* 2021;12:194. DOI PubMed PMC
 32. Zheng M, Zhang H, Dill DL, et al. The role of Abcb5 alleles in susceptibility to haloperidol-induced toxicity in mice and humans. *PLoS Med* 2015;12:e1001782. DOI PubMed PMC
 33. Schatton T, Yang J, Kleffel S, et al. ABCB5 identifies immunoregulatory dermal cells. *Cell Rep* 2015;12:1564-74. DOI PubMed PMC
 34. Vander Beken S, de Vries JC, Meier-Schiesser B, et al. Newly defined ATP-binding cassette subfamily B member 5 positive dermal mesenchymal stem cells promote healing of chronic iron-overload wounds via secretion of interleukin-1 receptor antagonist. *Stem Cells* 2019;37:1057-74. DOI PubMed PMC
 35. Kerstan A, Niebergall-Roth E, Esterlechner J, et al. Ex vivo-expanded highly pure ABCB5⁺ mesenchymal stromal cells as Good Manufacturing Practice-compliant autologous advanced therapy medicinal product for clinical use: process validation and first in-human data. *Cytotherapy* 2021;23:165-75. DOI PubMed PMC
 36. Kerstan A, Dieter K, Niebergall-Roth E, et al. Translational development of ABCB5⁺ dermal mesenchymal stem cells for therapeutic induction of angiogenesis in non-healing diabetic foot ulcers. *Stem Cell Res Ther* 2022;13:455. DOI PubMed PMC
 37. Begicevic RR, Falasca M. ABC transporters in cancer stem cells: beyond chemoresistance. *Int J Mol Sci* 2017;18:2362. DOI

[PubMed PMC](#)

38. Demeule M, Charfi C, Currie JC, et al. The TH1902 docetaxel peptide-drug conjugate inhibits xenografts growth of human SORT1-positive ovarian and triple-negative breast cancer stem-like cells. *Pharmaceutics* 2022;14:1910. [DOI PubMed PMC](#)
39. Zhang HL, Wang P, Lu MZ, Zhang SD, Zheng L. c-Myc maintains the self-renewal and chemoresistance properties of colon cancer stem cells. *Oncol Lett* 2019;17:4487-93. [DOI PubMed PMC](#)
40. Wilson BJ, Schatton T, Zhan Q, et al. ABCB5 identifies a therapy-refractory tumor cell population in colorectal cancer patients. *Cancer Res* 2011;71:5307-16. [DOI PubMed PMC](#)
41. Lee CAA, Banerjee P, Wilson BJ, et al. Targeting the ABC transporter ABCB5 sensitizes glioblastoma to temozolomide-induced apoptosis through a cell-cycle checkpoint regulation mechanism. *J Biol Chem* 2020;295:7774-88. [DOI PubMed PMC](#)
42. Cheung PF, Cheung TT, Yip CW, et al. Hepatic cancer stem cell marker granulin-epithelin precursor and β -catenin expression associate with recurrence in hepatocellular carcinoma. *Oncotarget* 2016;7:21644-57. [DOI PubMed PMC](#)
43. Wong NCL, Cheung PFY, Yip CW, et al. Antibody against granulin-epithelin precursor sensitizes hepatocellular carcinoma to chemotherapeutic agents. *Mol Cancer Ther* 2014;13:3001-12. [DOI PubMed](#)
44. Cheung PF, Cheng CK, Wong NC, et al. Granulin-epithelin precursor is an oncofetal protein defining hepatic cancer stem cells. *PLoS One* 2011;6:e28246. [DOI PubMed PMC](#)
45. Milosevic V, Kopecka J, Salaroglio IC, et al. Wnt/IL-1 β /IL-8 autocrine circuitries control chemoresistance in mesothelioma initiating cells by inducing ABCB5. *Int J Cancer* 2020;146:192-207. [DOI PubMed](#)
46. Grimm M, Krimmel M, Polligkeit J, et al. ABCB5 expression and cancer stem cell hypothesis in oral squamous cell carcinoma. *Eur J Cancer* 2012;48:3186-97. [DOI PubMed](#)
47. Wang Y, Teng JS. Increased multi-drug resistance and reduced apoptosis in osteosarcoma side population cells are crucial factors for tumor recurrence. *Exp Ther Med* 2016;12:81-6. [DOI PubMed PMC](#)
48. Nair RM, Balla MM, Khan I, Kalathur RKR, Kondaiah P, Vemuganti GK. In vitro characterization of CD133^{lo} cancer stem cells in Retinoblastoma Y79 cell line. *BMC Cancer* 2017;17:779. [DOI PubMed PMC](#)
49. Luo Y, Ellis LZ, Dallaglio K, et al. Side population cells from human melanoma tumors reveal diverse mechanisms for chemoresistance. *J Invest Dermatol* 2012;132:2440-50. [DOI PubMed PMC](#)
50. Sharma BK, Manglik V, Elias EG. Immuno-expression of human melanoma stem cell markers in tissues at different stages of the disease. *J Surg Res* 2010;163:e11-5. [DOI PubMed](#)
51. Schatton T, Murphy GF, Frank NY, et al. Identification of cells initiating human melanomas. *Nature* 2008;451:345-9. [DOI PubMed PMC](#)
52. Schatton T, Schütte U, Frank NY, et al. Modulation of T-cell activation by malignant melanoma initiating cells. *Cancer Res* 2010;70:697-708. [DOI PubMed PMC](#)
53. Wilson BJ, Saab KR, Ma J, et al. ABCB5 maintains melanoma-initiating cells through a proinflammatory cytokine signaling circuit. *Cancer Res* 2014;74:4196-207. [DOI PubMed PMC](#)
54. Wang S, Tang L, Lin J, et al. ABCB5 promotes melanoma metastasis through enhancing NF- κ B p65 protein stability. *Biochem Biophys Res Commun* 2017;492:18-26. [DOI PubMed](#)
55. Quintana E, Shackleton M, Foster HR, et al. Phenotypic heterogeneity among tumorigenic melanoma cells from patients that is reversible and not hierarchically organized. *Cancer Cell* 2010;18:510-23. [DOI PubMed PMC](#)
56. Cheli Y, Bonnazi VF, Jacquelin A, et al. CD271 is an imperfect marker for melanoma initiating cells. *Oncotarget* 2014;5:5272-83. [DOI PubMed PMC](#)
57. Girouard SD, Murphy GF. Melanoma stem cells: not rare, but well done. *Lab Invest* 2011;91:647-64. [DOI PubMed](#)
58. Jordan CT. Cancer stem cells: controversial or just misunderstood? *Cell Stem Cell* 2009;4:203-5. [DOI PubMed PMC](#)
59. Huang F, Santinon F, Flores González RE, Del Rincón SV. Melanoma plasticity: promoter of metastasis and resistance to therapy. *Front Oncol* 2021;11:756001. [DOI PubMed PMC](#)
60. Al Hmada Y, Brodell RT, Kharouf N, et al. Mechanisms of melanoma progression and treatment resistance: role of cancer stem-like cells. *Cancers* 2024;16:470. [DOI PubMed PMC](#)
61. Yao J, Yao X, Tian T, et al. ABCB5-ZEB1 axis promotes invasion and metastasis in breast cancer cells. *Oncol Res* 2017;25:305-16. [DOI PubMed PMC](#)
62. Hlaváč V, Václavíková R, Brynychová V, et al. Role of genetic variation in ABC transporters in breast cancer prognosis and therapy response. *Int J Mol Sci* 2020;21:9556. [DOI PubMed PMC](#)
63. Yang M, Li W, Fan D, et al. Expression of ABCB5 gene in hematological malignances and its significance. *Leuk Lymphoma* 2012;53:1211-5. [DOI PubMed](#)
64. Marzac C, Garrido E, Tang R, et al. ATP Binding Cassette transporters associated with chemoresistance: transcriptional profiling in extreme cohorts and their prognostic impact in a cohort of 281 acute myeloid leukemia patients. *Haematologica* 2011;96:1293-301. [DOI PubMed PMC](#)
65. Farawela HM, Khorshied MM, Kassem NM, Kassem HA, Zawam HM. The clinical relevance and prognostic significance of adenosine triphosphate ATP-binding cassette (ABCB5) and multidrug resistance (MDR1) genes expression in acute leukemia: an Egyptian study. *J Cancer Res Clin Oncol* 2014;140:1323-30. [DOI PubMed](#)
66. Leung IC, Chong CC, Cheung TT, et al. Genetic variation in ABCB5 associates with risk of hepatocellular carcinoma. *J Cell Mol Med* 2020;24:10705-13. [DOI PubMed PMC](#)

67. Chong CCN, Cheung ST, Cheung YS, et al. Novel biomarkers GEP/ABCB5 regulate response to adjuvant transarterial chemoembolization after curative hepatectomy for hepatocellular carcinoma. *Hepatobiliary Pancreat Dis Int* 2018;17:524-30. DOI PubMed
68. Cheung ST, Cheung PF, Cheng CK, Wong NC, Fan ST. Granulin-epithelin precursor and ATP-dependent binding cassette (ABC)B5 regulate liver cancer cell chemoresistance. *Gastroenterology* 2011;140:344-55. DOI PubMed
69. Govindan R, Ding L, Griffith M, et al. Genomic landscape of non-small cell lung cancer in smokers and never-smokers. *Cell* 2012;150:1121-34. DOI PubMed PMC
70. Wu Z, Zhao W, Yang Z, Wang YM, Dai Y, Chen LA. Novel resistance mechanisms to osimertinib analysed by whole-exome sequencing in non-small cell lung cancer. *Cancer Manag Res* 2021;13:2025-32. DOI PubMed PMC
71. Setia N, Abbas O, Sousa Y, Garb JL, Mahalingam M. Profiling of ABC transporters ABCB5, ABCF2 and nestin-positive stem cells in nevi, in situ and invasive melanoma. *Mod Pathol* 2012;25:1169-75. DOI PubMed
72. Vásquez-Moctezuma I, Meraza-Ríos MA, Villanueva-López CG, et al. ATP-binding cassette transporter ABCB5 gene is expressed with variability in malignant melanoma. *Actas Dermosifiliogr* 2010;101:341-8. DOI
73. Gambichler T, Petig AL, Stockfleth E, Stücker M. Expression of SOX10, ABCB5 and CD271 in melanocytic lesions and correlation with survival data of patients with melanoma. *Clin Exp Dermatol* 2016;41:709-16. DOI PubMed
74. Strobel SB, Machiraju D, Hülsmeier I, et al. Expression of potential targets for cell-based therapies on melanoma cells. *Life* 2021;11:269. DOI PubMed PMC
75. Kleffel S, Lee N, Lezcano C, et al. ABCB5-targeted chemoresistance reversal inhibits merkel cell carcinoma growth. *J Invest Dermatol* 2016;136:838-46. DOI PubMed PMC
76. Grimm M, Cetindis M, Lehmann M, et al. Apoptosis resistance-related ABCB5 and DNaseX (Apo10) expression in oral carcinogenesis. *Acta Odontol Scand* 2015;73:336-42. DOI PubMed
77. Li X, Hou YS. MiR-4282 contributes to inhibit pancreatic cancer metastasis by negatively interacting with ABCB5. *Eur Rev Med Pharmacol Sci* 2020;24:9915-23. DOI PubMed
78. Karas Zella MA, Sebastião APM, Collaço LM, et al. Prognostic significance of CD133 and ABCB5 expression in papillary thyroid carcinoma. *Eur J Histochem* 2020;64:3143. DOI PubMed
79. Heimerl S, Bosserhoff AK, Langmann T, Ecker J, Schmitz G. Mapping ATP-binding cassette transporter gene expression profiles in melanocytes and melanoma cells. *Melanoma Res* 2007;17:265-73. DOI PubMed
80. Szakács G, Annereau JP, Lababidi S, et al. Predicting drug sensitivity and resistance: profiling ABC transporter genes in cancer cells. *Cancer Cell* 2004;6:129-37. DOI PubMed
81. de Waard NE, Kolovou PE, McGuire SP, et al. Expression of multidrug resistance transporter ABCB5 in a murine model of human conjunctival melanoma. *Ocul Oncol Pathol* 2015;1:182-9. DOI PubMed PMC
82. Stockwin LH. Alveolar soft-part sarcoma (ASPS) resembles a mesenchymal stromal progenitor: evidence from meta-analysis of transcriptomic data. *PeerJ* 2020;8:e9394. DOI PubMed PMC
83. Gasser M, Kim M, Rehder R, et al. Clinical significance of disseminated pluripotent tumor cell signature expression in the bone marrow from patients with colorectal cancer. *J Cancer Sci Ther* 2017;9:669-74. DOI PubMed PMC
84. Guo Q, Grimmig T, Gonzalez G, et al. ATP-binding cassette member B5 (ABCB5) promotes tumor cell invasiveness in human colorectal cancer. *J Biol Chem* 2018;293:11166-78. DOI PubMed PMC
85. Shang F, Wang Y, Shi Z, Deng Z, Ma J. Development of a signature based on eight metastatic-related genes for prognosis of GC patients. *Mol Biotechnol* 2023;65:1796-808. DOI PubMed PMC
86. Reid AL, Millward M, Pearce R, et al. Markers of circulating tumour cells in the peripheral blood of patients with melanoma correlate with disease recurrence and progression. *Br J Dermatol* 2013;168:85-92. DOI PubMed PMC
87. Rapanotti MC, Campione E, Suarez Viguria TM, et al. Stem-mesenchymal signature cell genes detected in heterogeneous circulating melanoma cells correlate with disease stage in melanoma patients. *Front Mol Biosci* 2020;7:92. DOI PubMed PMC
88. Jones RM, Melton PE, Pinese M, et al; International Sarcoma Kindred Study. Identification of novel sarcoma risk genes using a two-stage genome wide DNA sequencing strategy in cancer cluster families and population case and control cohorts. *BMC Med Genet* 2019;20:69. DOI PubMed PMC
89. Lin JY, Zhang M, Schatton T, et al. Genetically determined ABCB5 functionality correlates with pigmentation phenotype and melanoma risk. *Biochem Biophys Res Commun* 2013;436:536-42. DOI PubMed PMC
90. Bertolotto C, Lesueur F, Giuliano S, et al; French Familial Melanoma Study Group. A SUMOylation-defective MITF germline mutation predisposes to melanoma and renal carcinoma. *Nature* 2011;480:94-8. DOI PubMed
91. Kugimiya N, Nishimoto A, Hosoyama T, et al. The c-MYC-ABCB5 axis plays a pivotal role in 5-fluorouracil resistance in human colon cancer cells. *J Cell Mol Med* 2015;19:1569-81. DOI PubMed PMC
92. Sakil HAM, Stantic M, Wolfsberger J, Brage SE, Hansson J, Wilhelm MT. ΔNp73 regulates the expression of the multidrug-resistance genes ABCB1 and ABCB5 in breast cancer and melanoma cells - a short report. *Cell Oncol* 2017;40:631-8. DOI PubMed PMC
93. Yang G, Jiang O, Ling D, et al. MicroRNA-522 reverses drug resistance of doxorubicin-induced HT29 colon cancer cell by targeting ABCB5. *Mol Med Rep* 2015;12:3930-6. DOI PubMed
94. Kadioglu O, Saeed MEM, Munder M, Spuller A, Greten HJ, Efferth T. Effect of ABC transporter expression and mutational status on survival rates of cancer patients. *Biomed Pharmacother* 2020;131:110718. DOI PubMed

95. Sana G, Madigan JP, Gartner JJ, et al. Exome sequencing of ABCB5 identifies recurrent melanoma mutations that result in increased proliferative and invasive capacities. *J Invest Dermatol* 2019;139:1985-92.e10. DOI PubMed PMC
96. Liu Z, Gao J, Gu R, et al. Comprehensive analysis of transcriptomics and genetic alterations identifies potential mechanisms underlying anthracycline therapy resistance in breast cancer. *Biomolecules* 2022;12:1834. DOI PubMed PMC
97. Huang Y, Anderle P, Bussey KJ, et al. Membrane transporters and channels: role of the transportome in cancer chemosensitivity and chemoresistance. *Cancer Res* 2004;64:4294-301. DOI PubMed
98. Yang JY, Ha SA, Yang YS, Kim JW. p-Glycoprotein ABCB5 and YB-1 expression plays a role in increased heterogeneity of breast cancer cells: correlations with cell fusion and doxorubicin resistance. *BMC Cancer* 2010;10:388. DOI PubMed PMC
99. Wozniak M, Szulawska-Mroczek A, Hartman M, Nejc D, Czyz M. Parthenolide complements the cell death-inducing activity of doxorubicin in melanoma cells. *Anticancer Res* 2013;33:3205-12. PubMed
100. Xiao J, Egger ME, McMasters KM, Hao H. Differential expression of ABCB5 in BRAF inhibitor-resistant melanoma cell lines. *BMC Cancer* 2018;18:675. DOI PubMed PMC
101. Lehne G, Grasmö-Wendler UH, Berner JM, et al. Upregulation of stem cell genes in multidrug resistant K562 leukemia cells. *Leuk Res* 2009;33:1379-85. DOI PubMed
102. Lu X, Xiang Y, Yang G, Zhang L, Wang H, Zhong S. Transcriptomic characterization of zebrafish larvae in response to mercury exposure. *Comp Biochem Physiol C Toxicol Pharmacol* 2017;192:40-9. DOI PubMed
103. El-Khattouti A, Sheehan NT, Monico J, et al. CD133⁺ melanoma subpopulation acquired resistance to caffeic acid phenethyl ester-induced apoptosis is attributed to the elevated expression of ABCB5: significance for melanoma treatment. *Cancer Lett* 2015;357:83-104. DOI PubMed
104. Tangella LP, Arooj M, Deplazes E, Gray ES, Mancera RL. Identification and characterisation of putative drug binding sites in human ATP-binding cassette B5 (ABCB5) transporter. *Comput Struct Biotechnol J* 2021;19:691-704. DOI PubMed PMC
105. Fukunaga-Kalabis M, Martinez G, Nguyen TK, et al. Tenascin-C promotes melanoma progression by maintaining the ABCB5-positive side population. *Oncogene* 2010;29:6115-24. DOI PubMed PMC
106. Kasica N, Jakubowski P, Kaleczyc J. P-glycoprotein inhibitor tariquidar plays an important regulatory role in pigmentation in larval zebrafish. *Cells* 2021;10:690. DOI PubMed PMC
107. Kondo S, Hongama K, Hanaya K, et al. Upregulation of cellular glutathione levels in human ABCB5- and murine Abcb5-transfected cells. *BMC Pharmacol Toxicol* 2015;16:37. DOI PubMed PMC
108. Kondo S, Kato Y, Minagawa S, Sugimoto Y. STAT1 upregulates glutaminase and modulates amino acids and glutathione metabolism. *Biochem Biophys Res Commun* 2020;523:672-7. DOI PubMed
109. Reschly EJ, Bainy AC, Mattos JJ, et al. Functional evolution of the vitamin D and pregnane X receptors. *BMC Evol Biol* 2007;7:222. DOI PubMed PMC
110. Chen L, Luo Y, Zhang C, et al. Trifloxystrobin induced developmental toxicity by disturbing the ABC transporters, carbohydrate and lipid metabolism in adult zebrafish. *Chemosphere* 2024;349:140747. DOI PubMed
111. Lutz NW, Banerjee P, Wilson BJ, Ma J, Cozzone PJ, Frank MH. Expression of cell-surface marker ABCB5 causes characteristic modifications of glucose, amino acid and phospholipid metabolism in the G3361 melanoma-initiating cell line. *PLoS One* 2016;11:e0161803. DOI PubMed PMC
112. Wadén K, Karlöf E, Narayanan S, et al. Clinical risk scores for stroke correlate with molecular signatures of vulnerability in symptomatic carotid patients. *iScience* 2022;25:104219. DOI PubMed PMC
113. Ibanez L, Heitsch L, Carrera C, et al. Multi-ancestry GWAS reveals excitotoxicity associated with outcome after ischaemic stroke. *Brain* 2022;145:2394-406. DOI PubMed PMC
114. Yang D, Li Z, Gao G, et al. Combined analysis of surface protein profile and microRNA expression profile of exosomes derived from brain microvascular endothelial cells in early cerebral ischemia. *ACS Omega* 2021;6:22410-21. DOI PubMed PMC
115. Deng X, Sabino EC, Cunha-Neto E, et al; REDSII Chagas Study Group from the NHLBI Retrovirus Epidemiology Donor Study-II Component International. Genome wide association study (GWAS) of Chagas cardiomyopathy in Trypanosoma cruzi seropositive subjects. *PLoS One* 2013;8:e79629. DOI PubMed PMC
116. Glessner JT, Bradfield JP, Wang K, et al. A genome-wide study reveals copy number variants exclusive to childhood obesity cases. *Am J Hum Genet* 2010;87:661-6. DOI PubMed PMC
117. McCaffrey TA, St Laurent G 3rd, Shtokalo D, et al. Biomarker discovery in attention deficit hyperactivity disorder: RNA sequencing of whole blood in discordant twin and case-controlled cohorts. *BMC Med Genomics* 2020;13:160. DOI PubMed PMC