

RESEARCH OUTPUTS / RÉSULTATS DE RECHERCHE

Tip-geometry enhanced cooling of field emission from the n-type semiconductor

Chung, Moon; Choi, Jin-Young; Mayer, Alexandre; Miskovsky, Nicholas; Cutler, Paul H

Published in:
Applied Physics Letters

DOI:
[10.1063/1.4866339](https://doi.org/10.1063/1.4866339)

Publication date:
2014

Document Version
Early version, also known as pre-print

[Link to publication](#)

Citation for published version (HARVARD):

Chung, M, Choi, J-Y, Mayer, A, Miskovsky, N & Cutler, PH 2014, 'Tip-geometry enhanced cooling of field emission from the n-type semiconductor', *Applied Physics Letters*, vol. 104, pp. 083502.
<https://doi.org/10.1063/1.4866339>

General rights

Copyright and moral rights for the publications made accessible in the public portal are retained by the authors and/or other copyright owners and it is a condition of accessing publications that users recognise and abide by the legal requirements associated with these rights.

- Users may download and print one copy of any publication from the public portal for the purpose of private study or research.
- You may not further distribute the material or use it for any profit-making activity or commercial gain
- You may freely distribute the URL identifying the publication in the public portal ?

Take down policy

If you believe that this document breaches copyright please contact us providing details, and we will remove access to the work immediately and investigate your claim.

Tip-geometry enhanced cooling of field emission from the n-type semiconductor

M. S. Chung^{1*}, J. Y. Choi¹, A. Mayer², N. M. Miskovsky³, and P. H. Cutler³

¹Department of Physics, University of Ulsan, Ulsan 680-749, Republic of Korea

²FUNDP, University of Namur, Rue de Bruxelles 61, B-5000 Namur, Belgium

³Department of Physics, Pennsylvania State University, University Park, PA 16802, USA

The cooling effect of field emission from an n-type semiconductor was theoretically investigated in quest for a solid state cooler. The vacuum potential was exactly expressed in terms of the semiconductor cathode geometry. This led to the more accurate configuration-dependent calculations of the energy exchange and the cooling power. A sharp tip of semiconductor yielded either a large field emission current density or a large energy exchange. An optimized configuration of n-Si cathode produced a meaningful electron emission cooling, especially at high temperatures.

Field emission undergoes the energy exchange process. Due to the Nottingham effect, a cathode is heated or cooled according to temperature T and field F .¹⁻³ Half a century ago, the inversion temperature T_i of the tungsten cathode was measured to vary from 500 K to over 1000 K as a function of F .^{4,5} Even though the energy exchange process was not well described, many theoretical calculations of T_i were made to be in reasonable agreement with the measured values of T_i .^{3,6} The high value of T_i results from the planar tip of a metallic cathode. For the same reason, the low value of T_i is accessible by the use of a sharp tip which produces a thin and shallow vacuum barrier so as to filter high-energy electrons in quantum tunneling. Thus Fisher's group^{7,8} used carbon nanotube tips to obtain a noticeable cooling at room T but unlikely made a success. This might reflect that a metallic cathode can yield no useful cooling at room T owing to the half-filled band, regardless of the tip sharpness. It was once suggested that thermionic (or thermal-field) emission from metal would serve as a new method of refrigeration.⁹⁻¹³ However, thermionic cooling can be achieved only at very high temperatures and very low values of work function, which seems to be unrealistic.⁹

Recently, Chung et al.¹⁴ have developed a formal theory for the energy exchange in field emission from the n-type semiconductors in consideration of the configuration shown in Fig. 1. The theory predicts $T_i=0$ K even for a planar tip, implying that the Nottingham effect yields cooling at all T . In the previous calculation,¹⁵ we used the formal theory to obtain the Nottingham effect comparable to the Peltier effect for the n-type PbTe. In the current work for

*Electronic mail: mschung@ulsan.ac.kr

the n-type Si semiconductor, we apply the same scheme along with the sharp tip effect.^{7,16}

When a bias V is applied between a planar semiconductor and a planar metallic anode with separation of d , the potential energy in vacuum is given by^{7,17}

$$U^0(x) = \chi + U_s - \gamma \frac{e^2}{4x} - eF_0x, \quad (1)$$

where $F_0 = V/d$, $\gamma = (\kappa - 1)/(\kappa + 1)$ with κ being the dielectric constant, χ is the electron affinity, U_s is the band bending due to field penetration,¹⁸ and x is the distance from the cathode. Here, the last two terms $\gamma e^2/4x (\equiv U_i^0(x))$ and $-eF_0x (\equiv U_a^0(x))$ are the image interaction and the applied potential energy, respectively. The superscript 0 indicates a planar tip. When $U_s = 0$ and $\gamma = 1$, Eq. (2) becomes the form for a metallic tip.

In order to obtain the vacuum potential energy $U(x)$ for a non-planar tip, we consider a sphere of radius R instead of a planar tip. By modifying each terms of $U^0(x)$, we can find a full form of $U(x)$. The first two terms in the right-hand side of Eq. (1), $\chi + U_s$, remains almost unchanged because of material properties. The third is changed to be a factorable form $U_i(x) = U_i^0(x)/(1 + 0.5x/R)$. By assuming even the anode to be a sphere of radius $R + d$, we can obtain the fourth in a factorable form $U_a(x) = U_a^0(x)(1 + d/R)/(1 + x/R)$. Here, d represents the tip-anode distance. The assumption of the anode configuration holds good for $d \gg R$, which is the case. In all, we have

$$U(x) = \chi + U_s - \gamma \frac{e^2}{4x} \frac{1}{1 + 0.5x/R} - eF_0x \frac{1 + d/R}{1 + x/R}, \quad 0 < x < d. \quad (2)$$

This is the vacuum potential energy for a spherical semiconductor cathode. Here, U_s is numerically obtained in the calculation of the potential energy in the semiconductor. It is clear that $U(x)$ is reduced to $U^0(x)$ in the limit $R \rightarrow \infty$. The comparison between $U(x)$ and $U^0(x)$ makes the field at the spherical surface given by $F = F_0(1 + d/R) = V(1/d + 1/R) \approx V/R$. The last approximation is almost exact since the current calculation was made for $R < 2$ nm and $d = 1000$ nm.

We use Eq. (2) to calculate $U(x)$ for $x > 0$ (in vacuum) at $R = \infty, 2.0, 0.5$ and 0.25 nm. To visualize the effect of the barrier on tunneling, we take $V = 1000$ volts for $R = \infty$ and $V = 4.0$ volts for $R = \text{finite}$. We set $d = 1000$ nm and the carrier concentration $n = 10^{19} \text{ cm}^{-3}$ through the current work. The obtained $U(x)$ are shown in Fig. 2. When $R = \infty$ (dotted line), $U(x)$ falls down by the value of $V (=1000 \text{ volts})$ linearly over d . When R is finite (solid lines), $U(x)$ falls down more rapidly for small x and more slowly for large x even if the total fall is equal to $V (=4 \text{ volts})$. The value of $V = 4.0$ volts is chosen because χ is 4.05 eV for Si. It is shown that the smaller the radius, the better the barrier has its role to filter high-energy electrons in tunneling. Therefore, we take R as small as possible.^{16,19}

For $-\infty < x < 0$ (in the semiconductor region), we obtained $U(x)$ by solving the Poisson equation numerically. This led to find the numerical values of $U_s = U(x = 0)$. When the bias of $V = 4.0$ volts is applied across the gap between tip and anode, we have $U_s = -0.13, -0.36$ and -0.61 eV for $R = 2.0, 0.5,$ and 0.25 nm , respectively. For $V = 1000$ volts and $R = \infty$, we have $U_s = -0.08 \text{ eV}$. Since it represents the lowering of the barrier height, U_s is crucial in tunneling. Once $U(x)$ is given for $-\infty < x < d$, we used the scheme of Lui and Fukuma²⁰ to make the more exact calculation of the transmission coefficient $D(\epsilon_x)$ for an electron of normal energy ϵ_x . It is assumed that F was applied in the x -direction.

Field emission consists of electron emission and replacement. Replacement is meant by the process that injected electrons occupy the same number of empty states as evacuated by emission. If the conduction band makes a major contribution, then the field emission current density j is given by

$$j = \int_{U_s}^{\infty} j_e(\epsilon) d\epsilon, \quad (3)$$

where $j_e(\epsilon)$ is the field electron energy distribution. The calculation of $j_e(\epsilon)$ is made using the expression¹⁴ $j_e(\epsilon) = (e/2\pi^2\hbar)f(\epsilon) \int D(\epsilon_x) dk_y dk_z$, where $f(\epsilon)$ is the Fermi distribution, and $\mathbf{k} = (k_x, k_y, k_z)$ the electron wave vector. It is known that tunneling in question takes place in a shorter time than thermal excitation. Electron emission should be a factor to evacuate energy states along with thermal excitation. Thus we write the replacement electron energy distribution in the form¹⁴ $j_r(\epsilon) = (e/2\pi^2\hbar)f(\epsilon) \int dk_y dk_z (1 - f(\epsilon) + f(\epsilon)D(\epsilon_x))$. We use Eq. (3) calculate j for $R = 0.25, 0.5,$ and 1.0 nm . The obtained j are shown as a function of V at $T = 300$ (dotted

line) and 600(solid) K in Fig. 3. For $R=0.25$ nm, j is almost saturated at $V = \chi + E_g \approx 5.2$ volts, where $E_g = 1.12$ for Si. For $R \geq 0.5$ nm, the saturated j can be produced by the bias $V \geq \chi + E_g$, which is not desirable because the valence band may contribute. This is the main reason why we take R as small as 0.25 nm.

When field emission is operated in steady state, the emission and replacement processes together yield the energy exchange

$$\Delta\varepsilon = \langle \varepsilon_e \rangle - \langle \varepsilon_r \rangle, \quad (4)$$

where $\langle \varepsilon_e \rangle$ and $\langle \varepsilon_r \rangle$ are the average energies of the field and replacement electrons. We evaluated both $\langle \varepsilon_e \rangle$ and $\langle \varepsilon_r \rangle$ using $j_e(\varepsilon)$ and $j_r(\varepsilon)$ as the weighting factors, respectively. The obtained $\Delta\varepsilon$ are shown as a function of T and V in Fig. 4. It is seen that $\Delta\varepsilon$ decreases with increasing V at $T = \text{constant}$. For small V (i.e., weak F), the barrier is so thick that only high energy electrons can make a significant tunneling. For large V (i.e. strong F), the barrier becomes so thin that even low energy electrons can tunnel considerably. This implies that $\langle \varepsilon_e \rangle$ is large for weak V and small for strong V . On the other hand, $\langle \varepsilon_r \rangle$ is almost constant because replacement is made mainly about the bottom levels of the conduction band, irrespective of V . For $V = 4.0$ volts (i.e., $F = 1.6$ V/nm), $\Delta\varepsilon$ is approximately equal to 0.40, 0.58, and 0.71 eV at $T = 300, 600,$ and 900 K, respectively. Such T -dependences of $\Delta\varepsilon$ are a little more enhanced than the Fermi distribution through tunneling. It is worthwhile to note that $\Delta\varepsilon$ is positive for all V at all T .

Equation (4) denotes the positive $\Delta\varepsilon$ as the energy loss of the cathode. Then the cooling power density (i.e., cooling power per unit area) is the product of the energy loss per electron and the number of electrons emitted per unit time per unit area, $\Delta\varepsilon(j/e)$. On the other hand, j also produces the Joule heating $\rho L j^2$, where ρ and L are the resistivity and length of the cathode. Thus the net cooling power density, Γ , produced about the emission site is^{9,14}

$$\Gamma = (\Delta\varepsilon/e)j - \rho L j^2. \quad (5)$$

Here, the T -dependence of ρ is taken into account using the fitting relation.²¹⁻²³ Then the

calculation of Γ is straightforward, where we choose $L=0.1$ cm. The obtained Γ are shown as a function of V in Fig. 5. The maximum value of Γ are approximately 398, 3105, and 10000 watts/cm² at $T=300$, 600, and 900 K, respectively. The maximum is located about $V=5.2$ volts (i.e., $F=20.8$ V/nm) at 300 K, shifting very slightly to the left with increasing T . The corresponding current density j_m are 6.4, 13.2, and 21.8×10^4 A/cm² at each T . Cooling continues until j reaches twice j_m , which is very large in comparison with typical values in a normal life. This implies that field emission from the n-Si cathode always yields cooling, in usual. Even if so, cooling is unlikely large enough to cool down electronic devices at room T . At high T , however, both $\Delta\varepsilon$ and j are large to yield a meaningful value of Γ . When the bias of $V=4.5$ volts was applied, we obtained pairs ($\Delta\varepsilon=0.05$ eV, $j=44$ A/cm²) for $\Gamma=2.0$ W/cm² at $T=300$ K, ($\Delta\varepsilon=0.18$ eV, $j=424$ A/cm²) for $\Gamma=74.7$ W/cm² at $T=600$ K, and ($\Delta\varepsilon=0.30$ eV, $j=2375$ A/cm²) for $\Gamma=713$ W/cm² at $T=900$ K.

It is now supposed that a field emission cooler produces the (net) cooling power Φ , which is equal to the product of Γ and the emission area A : $\Phi = \Gamma A$. The performance of the cooler is given in terms of the efficiency

$$\eta = \frac{\Phi}{IV} = \frac{\Gamma}{jV}, \quad (6)$$

where $I = jA$, the current of the circuit. For small V , j is so small that η becomes $\Delta\varepsilon/eV$ since Γ approaches $\Delta\varepsilon(j/e)$. Since $\Delta\varepsilon$ increases continuously with decreasing V , η can reach a very large value, say the thermodynamic limit, for a very small V . By Eq. (5), Γ increases at the less rate than j as V increases. This means that η is small for large V even if Γ is large. It may be a drawback of field emission cooling that either Γ or η only can be large over the entire range of V . As mentioned above, however, there are two factors, T and R , to improve cooling. At high T , Γ and η can altogether be large. For small R , η can become large since j is large even for small V . Niche values of $\Delta\varepsilon$, Γ , and η are shown in Table 1. For $V=4.0$ volts, we obtain $\eta=10$ and 18 % at $T=300$ and 900 K, respectively. For $V=4.5$ volts, we have $\eta=1.0$ and 6.7 % at $T=300$ and 900 K, respectively.

To figure out the supposed cooler in more detail (see Fig. 1), we need to estimate Φ and I numerically with a certain choice of A . The exact value of A can not be determined since F (or j) varies from position to position over the region of emission.¹⁶ If j is assumed to be constant over A , we can take a reasonable value of A . As a typical device, we consider the Spindt-type²⁴ cathode which has an array of 10^9 tips per centimeter square and a current of 1 nA

per tip. This make it possible to consider $I (= jA)$ in the range from 0.1 mA to 100 A . This will make us find $A \approx 0.01 \text{ cm}^2$. When the bias of $V = 4.5$ volts is applied, we have $\Phi = \Gamma A \approx 0.02$, 0.75 and 7.1 watts at $T = 300$, 600, and 900 K, respectively. For $V = 5.0$ volts, we have $\Phi \approx 2.3$, 21.6 and 80.3 watts at the same above temperatures, respectively. It looks that the currently obtained Nottingham effect is comparable to the Peltier effect.^{15,23} According to the situation, either one may be more effective than the other in cooling an electronic device.

ACKNOWLEDGMENT

This research was supported by the Basic Science Research Program through National Research Foundation of Korea funded by the Ministry of Education, Science and Technology (Grant No. 2011-0009500).

References

- ¹ W. Nottingham, Phys. Rev. **59**, 907 (1941).
- ² G. M. Fleming and J. E. Henderson, Phys. Rev. **58**, 887 (1940).
- ³ F. M. Charbonnier, R. W. Strayer, L. W. Swanson, and E. E. Martin, Phys. Rev. Lett. **13**, 397 (1964).
- ⁴ L. W. Swanson, L. C. Crouser, and F. M. Charbonnier, Phys. Rev. **151**, 327 (1966).
- ⁵ M. Drechsler, Z. Naturforsch. A **18**, 1367 (1963).
- ⁶ I. Engle and P. H. Cutler, Surf. Sci. **12**, 208 (1968).
- ⁷ T. S. Fisher and D. G. Walker, Trans. ASME vol. **124**, 954 (2002).
- ⁸ T. L. Westover and T. S. Fisher, Heat Transfer Eng. **29**, 395 (2008).
- ⁹ G. D. Mahan, J. Appl. Phys. **76**, 4362 (1994).
- ¹⁰ Y. Hishnuma, T. H. Geballe, B. Y. Moyzhes, and T. W. Kenny, Appl. Phys. Lett. **78**, 2572 (2001).
- ¹¹ A. Shakouri, C. LaBounty, J. Piprek, P. Abraham, and J. E. Bowers, Appl. Phys. Lett. **74**, 88 (1999).
- ¹² G. S. Nolas and H. J. Goldsmid, J. Appl. Phys. **85**, 4066 (1999).
- ¹³ A. N. Korotkov and K. K. Likharev, Appl. Phys. Lett. **75**, 2491 (1999).
- ¹⁴ M. S. Chung, S. C. Hong, A. Mayer, P. H. Cutler, B. L. Weiss, and N. M. Miskovsky, Appl. Phys. Lett. **92**, 083505 (2008).
- ¹⁵ M. S. Chung, A. Mayer, B. L. Weiss, N. M. Miskovsky, and P. H. Cutler, Appl. Phys. Lett. **98**, 243502 (2011).
- ¹⁶ K. L. Jensen and E. G. Zaidman, J. Vac. Sci. Technol. B **13**, 511 (1995).

- ¹⁷ A. Modinos, *Field, Thermionic, and Secondary Electron Emission Spectroscopy* (Plenum, New York, 1984).
- ¹⁸ T. T. Tsong, *Surf. Sci.* **81**, 28 (1979).
- ¹⁹ Vu T. Binh, S. T. Purcell, N. Garcia, and J. Doglioni, *Phys. Rev. Lett.* **69**, 2527 (1992).
- ²⁰ W. W. Lui and M. Fukuma, *J. Appl. Phys.* **60**, 1555 (1986).
- ²¹ N. D. Arora, J. R. Hauser, and D. J. Roulston, *IEEE Trans. Electron Devices* vol. **ED-29**, 292 (1982).
- ²² O. Madelung, *Semiconductors Basic Data*, 2nd ed., (Springer, New York, 1996), p.200.
- ²³ A. Stranz, J. Kähler, A. Waag, and E. Peiner, *J. Electronic Mater.* **42**, 2381 (2013).
- ²⁴ I. Brodie and C. A. Spindt, *Vacuum Microelectronics*, *Advances in Physics* vol. **83** (Academic Press, New York, 1992), p.1.

Table 1. Cooling Characteristics. Cooling of field emission from the n-type Si tip is described by the energy exchange $\Delta\varepsilon$, the power density Γ , and the efficiency η at temperature T and for the bias V . We take the tip radius $R = 0.25$ nm and the tip-anode distance $d = 1000$ nm.

| V (volts)=4.0 | $\Delta\varepsilon$ (eV) | Γ (W/cm ²) | η (%) | V (volts)=4.5 | $\Delta\varepsilon$ (eV) | Γ (W/cm ²) | η (%) |
|---------------|--------------------------|-------------------------------|------------|---------------|--------------------------|-------------------------------|------------|
| T (K)= 300 | 0.40 | 8.0×10^{-6} | 10 | T (K)= 300 | 0.05 | 2.0 | 1.0 |
| 600 | 0.58 | 0.17 | 15 | 600 | 0.18 | 74.7 | 3.9 |
| 900 | 0.71 | 15.7 | 18 | 900 | 0.30 | 712.5 | 6.7 |

Figure Captions

Fig. 1 Schematic of a Supposed Field Emission Cooler. Energy exchange process takes place between the n-type semiconductor cathode and the conduction electron. The positive energy exchange cools down a sample at temperature T .

Fig. 2 Vacuum Potential Energy U for a Spherical Cathode of N-Type Si. The potential falls down in a different way according to the bias V (in volts) and the tip radius R (in nm).

Fig. 3 Plot of Current Density j vs. Bias V . The j exhibits different Fowler-Nordheim plots according to the tip radius R and temperature T . The effect of R results from the enhanced field and the modified barrier.

Fig. 4 Plots of Exchange Energy $\Delta\varepsilon$ vs. Bias V . We set the tip radius $R = 0.25$ nm and the tip-anode distance $d = 1000$ nm. The $\Delta\varepsilon$ increases with decreasing V and increasing T .

Fig. 5 Plots of Cooling Power Density Γ vs. Bias V . The maximum cooling power increases rapidly with increasing T but is located about $V = 5.2$ volts with a slight T -dependence.

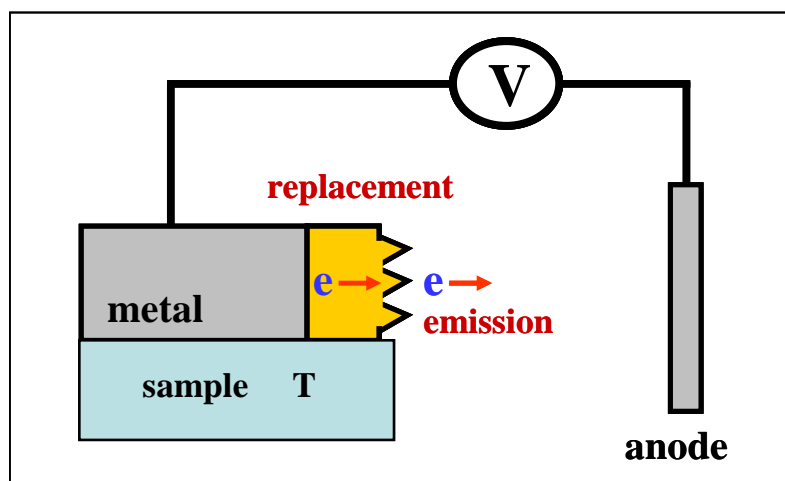

Fig. 1

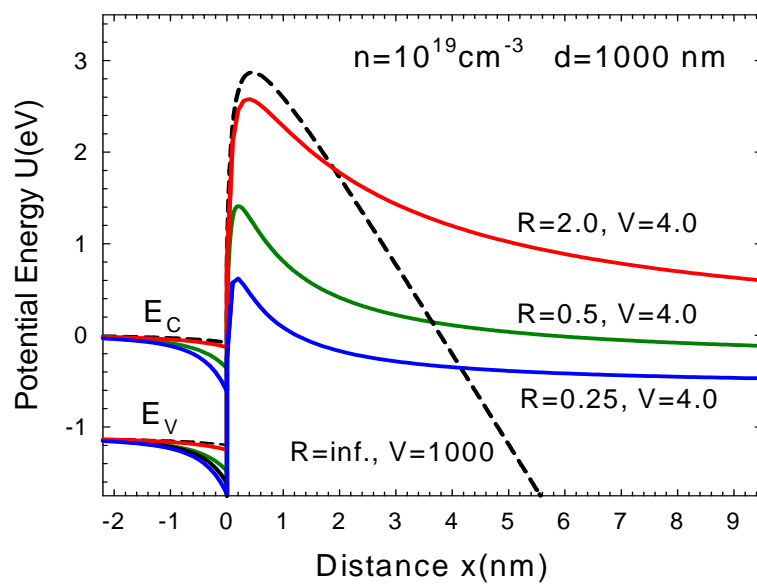

Fig. 2

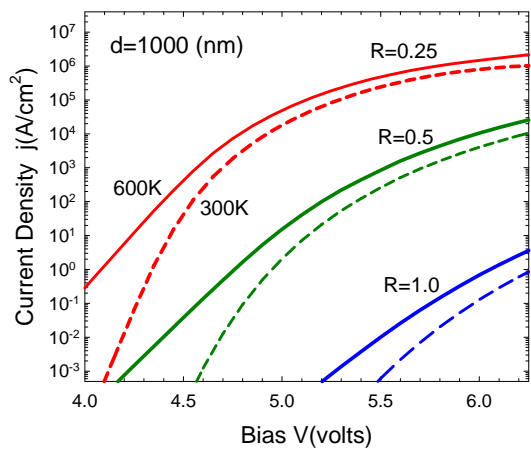

Fig. 3

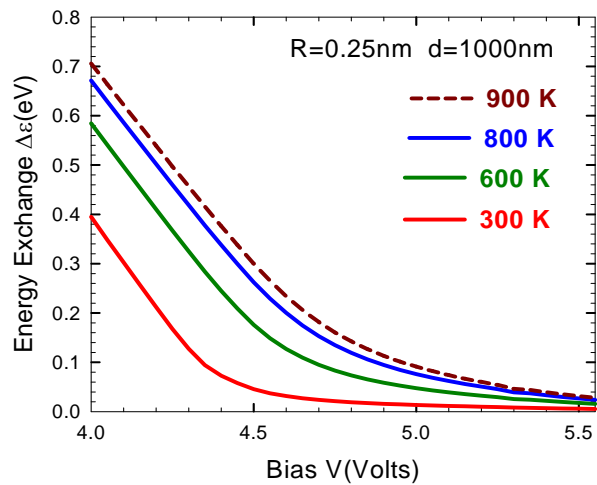

Fig. 4

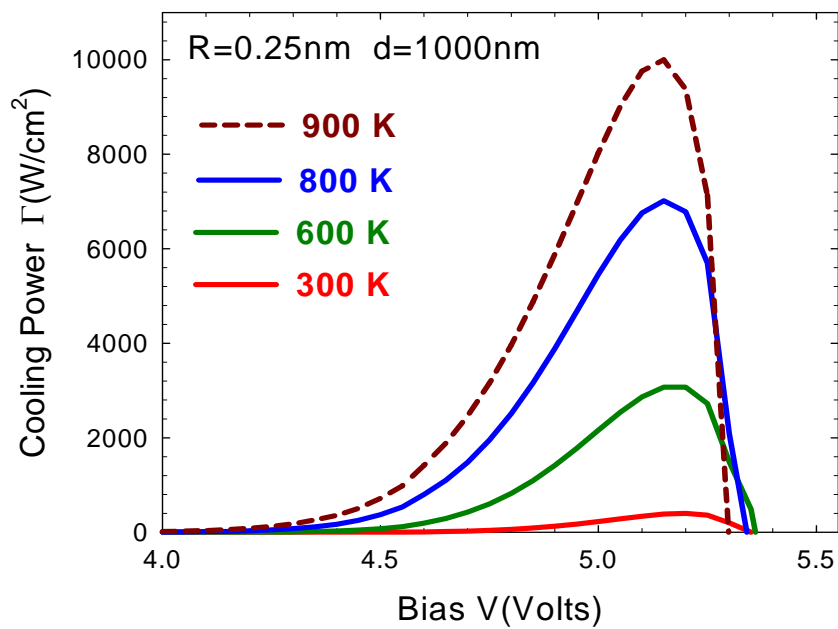

Fig. 5