

THESIS / THÈSE

MASTER IN BIOCHEMISTRY AND MOLECULAR AND CELLULAR BIOLOGY

Creation of a recombinant virus of Marek Disease Virus restoring the expression of the cellular micro-RNA gga-miR-126 in a model of viral induced tumorigenesis

HOSTYN, Pierre

Award date:
2018

Awarding institution:
University of Namur

[Link to publication](#)

General rights

Copyright and moral rights for the publications made accessible in the public portal are retained by the authors and/or other copyright owners and it is a condition of accessing publications that users recognise and abide by the legal requirements associated with these rights.

- Users may download and print one copy of any publication from the public portal for the purpose of private study or research.
- You may not further distribute the material or use it for any profit-making activity or commercial gain
- You may freely distribute the URL identifying the publication in the public portal ?

Take down policy

If you believe that this document breaches copyright please contact us providing details, and we will remove access to the work immediately and investigate your claim.



University of Namur

Faculty of Sciences

Creation of a recombinant virus of Marek Disease Virus restoring the expression of the cellular micro-RNA gga-miR-126 in a model of viral induced tumorigenesis

Master thesis presented to obtain

Academic degree of Master in Biochemistry and Molecular and Cellular biology

Pierre Hostyn

Integrated Veterinary Research Unit (IVRU)

Supervisors: Benoit Muylkens and Isabelle Gennart

January 2018

Faculty of Namur
FACULTY OF SCIENCE
Secretariat Department of Biology
Rue de Bruxelles 61 - 5000 NAMUR
Phone: + 32(0)81.72.44.18 - fax: + 32(0)81.72.44.20
E-mail: joelle.jonet@fundp.ac.be - <http://www.fundp.ac.be/fundp.html>

Creation of a recombinant virus of Marek Disease Virus restoring the expression of the cellular micro-RNA gga-miR-126 in a model of viral induced tumorigenesis

Pierre Hostyn

Résumé:

La maladie de Marek est une maladie lymphoproliférative du poulet dont l'agent causal est l' α -herpesvirus Gallid herpesvirus 2 (GaHV-2). Depuis quelques années, GaHV-2 est reconnu comme possédant un fort potentiel oncogénique. En effet, suite à sa phase latente au sein des lymphocytes T CD4, ces mêmes cellules subissent un processus de transformation tumorale. Cette lymphomagenèse induite par le GaHV-2 constitue un bon modèle animal pour l'étude de la tumorigenèse viro-induite. Des études préliminaires ont montré qu'au sein de lymphomes induits par GaHV-2, une dérégulation de certains micro-ARNs prenait place. Cette interférence avec l'expression normale des micro-ARNs cellulaires est une partie du mécanisme de la tumorigenèse. Une sous-expression du miR-126 cellulaire induite par l'infection de GaHV-2 a été démontrée au cours de précédentes études in vitro et in vivo réalisées par le laboratoire d'accueil. De plus, le miR-126 est suspecté de posséder un potentiel de suppresseur de tumeurs. Dans le but d'étudier la relation entre la répression du miR-126 (brin 3p) et le développement de tumeurs au sein de l'hôte infecté, un virus recombinant portant un système d'expression du miR-126 a été développé au cours de ce mémoire. La première partie du projet a permis de créer deux virus recombinants à partir d'une souche très virulente (RB1B) : l'un portant la séquence du miR-126 (RB1B+126wt), l'autre portant une version mutée de celui-ci (RB1B+126mut). La création de ces virus recombinants a été réalisée grâce à la technique de mutagenèse « en passant ». Au cours de la seconde partie de ce mémoire, ces génomes recombinants ont été transfectés au sein de fibroblastes d'embryon de poulets afin de les amplifier. Ces virus ont été stockés et titrés par immunofluorescence en prévision d'une éventuelle expérience in vivo afin d'étudier l'effet d'une surexpression du miR-126 au cours de l'infection par GaHV-2. Pour conclure, les premières analyses de quantification de la surexpression des miR-126 (wt et mut) montrent une importante surexpression. Afin de confirmer cette surexpression, une analyse plus poussée est en ce moment en cours de progression.

Master thesis in Biochemistry and Molecular and Cellular biology

January 2018

Promoteur: Benoit Muylkens

Acknowledgments:

First, I would like to thank Nathalie Kirschvink for welcoming me in the URVI of UNamur during this year.

Next, I would like to thank Benoît Muylkens who accepts me in his research team. I will also thank his availability, his precious advices and the time he takes for the correction of this master thesis.

I would address an especially thank you for Isabelle Gennart for her management, advices and support from my TFB to now the end of this master thesis. Thank you for support me in the bad times.

I would like to thank also Laetitia, Damien, Srdan, Nicolas, Noémie, Carine, Chantal, Marianne, Fanny, Gaston for the good ambiance in the lab.

Thanks to Nicolas Chalon to set the mood in the internship room.

A quick Thank you for all the internships of this year.

Finally, I will thank Margaux Simon, Maxime Mac'cord, Angèle Markey, Nicolas Hautphenne, Mathias Bracaval and the D59 for their support, their jokes and again their support.

Table of content

I.	Introduction :	6
I.1.	<i>The Herpesviridae family :</i>	6
I.1.1.	<i>General context :</i>	6
I.1.2.	<i>Classification of Herpesvirales order:</i>	7
I.1.2.1.	<i>Alphaherpesvirinae:</i>	7
I.1.2.2.	<i>Betaherpesvirinae:</i>	7
I.1.2.3.	<i>Gammaherpesvirinae:</i>	7
I.2.	<i>The Marek's Disease:</i>	8
I.2.1.	<i>General informations:</i>	8
I.2.2.	<i>Historical context:</i>	9
I.2.3.	<i>Vaccination of the Marek's disease :</i>	9
I.2.4.	<i>Clinical forms of the Marek's disease virus:</i>	10
I.2.5.	<i>Physio-pathology of the Marek's disease virus:</i>	10
I.2.5.1.	<i>The early productive phase:</i>	11
I.2.5.2.	<i>The latency phase:</i>	11
I.2.5.3.	<i>The late productive phase:</i>	11
I.2.5.4.	<i>The tumoral phase:</i>	11
I.3.	<i>MicroRNAs (miRNAs):</i>	12
I.3.1.	<i>General informations:</i>	12
I.3.2.	<i>Biosynthesis of miRNA:</i>	12
I.4.	<i>The miR-126:</i>	13
I.4.1.	<i>The host gene of miR-126, EGFL7:</i>	13
I.4.2.	<i>Importance of miR-126:</i>	13
I.4.3.	<i>Functions of miR-126:</i>	14
I.4.4.	<i>MiR-126 as tumor suppressor:</i>	14
I.5.	<i>The recombinant virus technology:</i>	15
I.6.	<i>Aim of the project:</i>	15
II.	Material and methods:	17
II.1.	<i>Cellular cultures methods:</i>	17
II.1.1.	<i>Primary CEF culture:</i>	17
II.1.2.	<i>Secondary CEF culture:</i>	17
II.2.	<i>Vectors:</i>	17
II.2.1.	<i>The pepKans2 plasmid:</i>	17
II.2.2.	<i>The pRB1B-5 bacmid:</i>	18

II.2.3.	<i>Promega PGEM®-T Easy plasmid and TA cloning:</i>	19
II.3.	<i>Bacteria strains:</i>	19
II.3.1.	<i>DH10B strain of E. coli:</i>	19
II.3.2.	<i>GS-1783 strain of E. coli:</i>	19
II.4.	<i>Molecular methods:</i>	20
II.4.1.	<i>High-fidelity amplification by NEB Q5®</i>	20
II.4.2.	<i>DNA digestion catalyzed by restriction enzymes (HpaI, NheI, KpnI):</i>	20
II.4.3.	<i>Purification on gel:</i>	20
II.4.4.	<i>Dephosphorylation of digested plasmids:</i>	20
II.4.5.	<i>Plasmid purification by Phenol/Chloroform:</i>	20
II.4.6.	<i>Ligation of PCR products (insert) into plasmids (vector):</i>	21
II.4.7.	<i>Electroporation of ligation products on DH10B strain of E. coli:</i>	21
II.4.8.	<i>PCR screening to detect positive colonies bearing the sequences of interest:</i>	21
II.4.9.	<i>Inducing of electrocompetence and RED system of GS-1783 strain:</i>	21
II.4.10.	<i>Restriction of the KanR cassette by induction of the Sce-I enzyme in GS-1783:</i>	22
II.4.11.	<i>MidiPrep of High-copy plasmid or Low-copy plasmid:</i>	22
II.4.12.	<i>Lipofection of bacmids in secondary CEF's:</i>	23
II.4.13.	<i>Titration of viral particles by Indirect Immunofluorescence:</i>	23
II.4.14.	<i>RNA extraction by TRI reagent:</i>	24
II.4.15.	<i>DNase treatment:</i>	25
II.4.16.	<i>RNA's purification by Phenol/Chloroform:</i>	25
II.4.17.	<i>Reverse transcription specific to miR-126-3p:</i>	25
II.4.18.	<i>Reverse Transcriptase- quantitative PCR (RT-qPCR) directed to miR-126-3p cDNA:</i>	26
III.	Results:	26
III.1.	<i>Development of a GaHV-2 recombinant virus to restore miR-126 expression:</i>	26
III.1.1.	<i>Development of miRNA expression system containing transient Kanamycin resistant gene.....</i>	27
III.1.2.	<i>Production of transfer amplicon (T.A.) to incorporate the miRNA expression system inside the viral bacmid pRB1B-5:</i>	28
III.1.3.	<i>Generation of wt-miR-126 or mut-miR-126 of recombinant RB1B bacmids by the "en passant" insertion mutagenesis:</i>	29
III.2.	<i>Amplification and titration of the recombinant viruses</i>	32
III.3.	<i>Assessment of miR-126 wt or miR-126 mut overexpression:</i>	33
IV.	Discussions:	34
V.	Perspectives of the project:	35
VI.	Bibliography	36

I. Introduction:

I.1. The Herpesviridae family:

I.1.1. General context:

Viruses belonging to the *Herpesviridae* family shares four characteristics: a core, a capsid, a tegument and an envelope (Roizman *et al.*, 1993). All herpesviruses possess within their core a double-strand (ds) DNA whose length varies between 120 to 250kbp (Roizman & Pellet, 2007). There are six classes of herpesviruses genomes, classified from the type A to the type F according to their genomic organization (Fig. 1) (Schyns *et al.*, 2002).

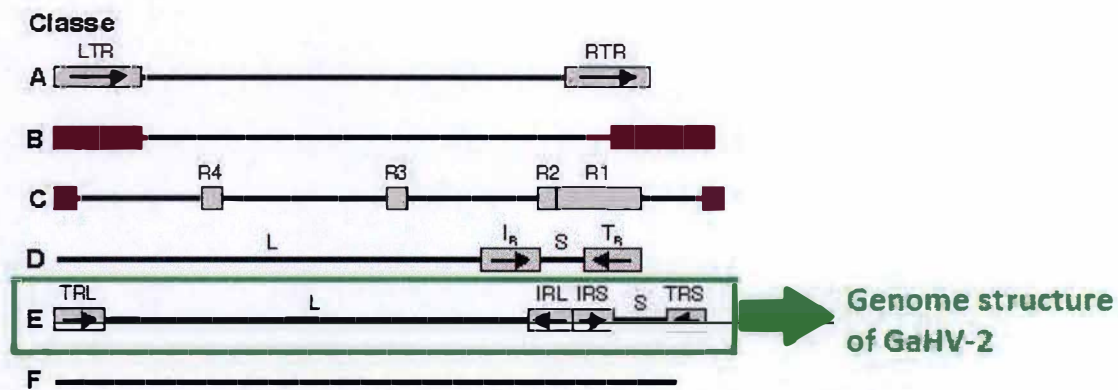

Figure 1: Representation of the diverse types of genomes in the *Herpesviridae* family. (A) *Herpesviridae* genome of type A composed by a long DNA sequence boarded by two terminal repeat regions: the left terminal repeat (LTR) and the right terminal repeat (RTR). (B) The terminal sequences are repeated with a variable number of repeats at both ends for the type B genome. (C) As for the type B, the type C genome possesses also variable terminal repeats. Four internal repeats domains (R1, R2, R3, R4) are present in this genome. (D) Type D genome is composed by a long (L) and a short (S) coding regions. The short region is boarded by an internal repeat (IR) and a terminal repeat (TR). (E) Type E genome composed by a long (L) and a short (S) coding regions. The long region is boarded by a terminal repeat long (TRL) and an internal repeat long (IRL). The short region is boarded by an internal repeat short (IRS) and a terminal repeat short (TRS). (F) Type F genome is composed by a unique long sequence without repeat regions. (Schyns *et al.*, 2002)

The size of herpesvirus particles varies between 120 nm to 260 nm. As mentioned previously, all herpesviruses virions are composed by 4 structures: the core, the capsid, the tegument and the envelope (Fig. 3). The core contains the viral ds DNA in a form of torus. This structure is hooked to the underside of the capsid by fibrils (Furlong *et al.*, 1972). All viruses of the *herpesvirales* order have a capsid of 100 nm diameter composed by 162 capsomeres. (Newcomb *et al.*, 1996; Davison *et al.*, 2005). The tegument is composed by proteins to ensure the interactions between the capsid and the envelop of virions. The envelope of herpesviruses is composed of several glycoproteins. These glycoproteins are more numerous in comparison to other enveloped viruses (Wildy & Watson, 1962). The life cycle of all herpesviruses is composed by 2 phases: the lytic and the latent phases. The lytic phase consists in the replication of viral particles while the latent phase consists in the dormancy of the viral infection. This latency is a major hallmark for all herpesviruses (Roizman & Pellet, 2007.).

I.1.2. Classification of Herpesvirales order:

Thanks to newly extensive nucleotide sequence data, the order *Herpesvirales* was created. This order includes 3 families. First, the *Herpesviridae* family retains viruses of mammals, birds and reptiles. Next to this first family, two newly families were identified: the *Alloherpesviridae* and the *Malacoherpesviridae*. The *Alloherpesviridae* family gathers viruses of fish and frogs and the *Malacoherpesviridae* is specific to bivalve molluscs (**Fig.2**) (Davison *et al.*, 2013).

The *Herpesviridae* family is subdivided into three sub-families based on their biological properties. These sub-families are the *Alpha-*, *Beta-* and the *Gammaherpesvirinae* (Roizman *et al.*, 1981).

I.1.2.1. Alphaherpesvirinae:

This sub-family is composed of four genera. These genera are the *Simplexvirus*, *Varicellovirus*, *Mardivirus* and *Iltovirus*. Some characteristics are used to classified viruses into the *Alphaherpesvirinae* sub-family such as a variable host range, a short reproductive cycle, an infection spreading rapidly in culture. In addition, *Alphaherpesvirinae* establish this latent infection primarily but not exclusively in sensory ganglia (McGeoch & Gatherer, 2005). Members of *Simplexvirus* (e.g. *Herpes Simplex Virus-1*, (HSV-1)) and *Varicellovirus* (e.g. *Varicella Zoster Virus*, (VZV)) infect mammalian hosts, while members of the *Mardivirus* (e.g. *Gallid herpesvirus 2*, (GaHV-2)) and *Iltovirus* (e.g. *Gallid herpesvirus 1*, (GaHV-1)) possess avian hosts (McGeoch & Gatherer, 2005) (**Fig.2**).

I.1.2.2. Betaherpesvirinae:

Four genera composed this sub-family. These are *Cytomegalovirus* (e.g. *Human Cytomegalovirus*, (HCMV)), *Muromegalovirus* (e.g. *Murine Cytomegalovirus*, (MCMV)), *Roseolovirus* (e.g. *Human Herpesvirus-6*, (HHV-6)) and *Proboscivirus* (e.g. *Elephantid Herpesvirus-1*, (EHV-1)). Members of this sub-family share some characteristics that allow their classification into *Betaherpesvirinae*. These characteristics are a long reproductive cycle, a slow infection spreading slowly in cell culture. Infected cells present a cytomegalia (enlargement of cells). The latent is formed in several cell types such as salivary cells, lymphoreticular cells and kidney cells (Roizman & Pellet, 2007) (**Fig. 2**).

I.1.2.3. Gammaherpesvirinae:

In the origin, this sub-family was divided in two genera: the *Lymphocryptovirus* (e.g. *Epstein-Barr Virus*, (EBV)) and the *Rhadinovirus* (e.g. *Human Herpesvirus-8*, (HHV-8)). For now, the *Rhadinovirus* genus is expanded with two new genera. These two genera are the *Macavirus* (e.g. *Ovine herpesvirus 2*, (OHV-2)) and the *Percavirus* (e.g. *Equid herpesvirus-2*, (EHV-2)) (McGeoch, *et al.*, 2006; Telford, *et al.*, 1995). Rhadinoviruses are specifically hosted by primates while Macaviruses are associated with the malignant catarrhal fever viruses of ruminants. Percaviruses are mainly hosted by perissodactyl (ungulates mammals) and carnivore species. Lymphocryptoviruses are specifically hosted by different mammals (Lacoste *et al.*, 2007). This sub-family is then composed by viruses that latently infect monocyte, dendritic

cells and usually either B and T lymphocytes in primarily mammalian hosts (Knipe *et al*, 2007) (Fig. 2).

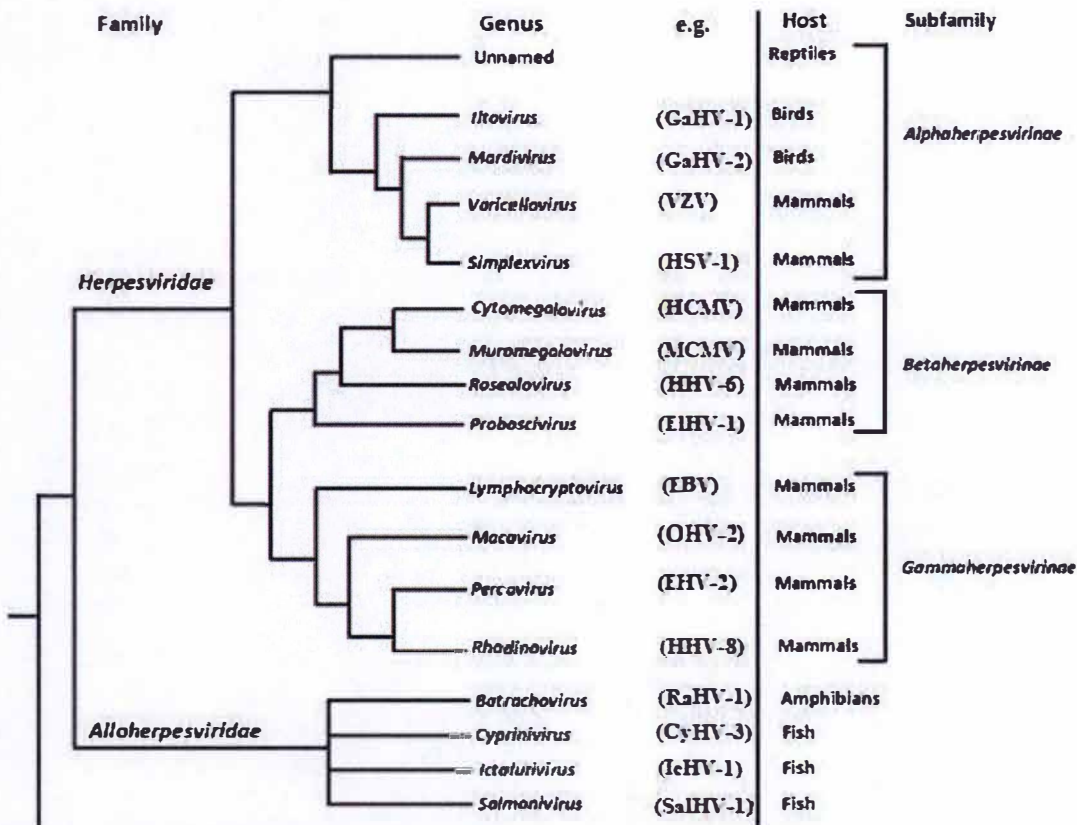

Figure 2: Classification of the *Herpesvirales* order. Representation of the classification inside the *Herpesvirales* order. The three families are exposed with their subfamilies and genus. Each genus is associated to its specific host.

I.2. The Marek’s Disease:
 I.2.1. General informations:

During this master thesis, the Marek’s disease was the focus of our attention. It’s a lymphoproliferative neoplastic disease of chicken induced by the infection of susceptible birds with oncogenic strains of *Gallid herpesvirus 2* (GaHV-2) (Fig. 3). This herpesvirus is part of the *Alphaherpesvirinae* sub-family and a member of the *Mardivirus* genus. Besides oncogenic genotype of GaHV-2 that are gathered in the serotype 1 of the Marek’s disease virus (MDV), several non-oncogenic genotypes are found. They are either classified in the species *Gallid herpesvirus-3* (serotype 2 or MDV-2) and in the species *Meleagrid herpesvirus 1* (MeHV-1) that naturally infects turkeys (serotype 3 or MDV-3). These non-oncogenic strains are used as live attenuated vaccines that are used to prevent the disease, but recent research shown that vaccination increases virulence of MDV and specifically enhances the transmission of highly virulent strains. (Atkins *et al.*, 2013; Read *et al.*, 2015).

The Marek's disease virus shows a *Herpesviridae* type E genome, composed by a unique long (UL) region and a unique short (US) region. The UL and US regions are respectively surrounded by a Terminal Repeat Long (TRL) and an Internal Repeat Long (IRL) or Terminal Repeat Short (TRS) an Internal Repeat Short (IRS) (Schyns *et al.*, 2002) (Fig. 1). Telomeric sequences composed by repetitions of the GGTTAG hexamers are present at the junction between the IRL and the IRS. These sequences are also present at the extremity of the genome (Kishi *et al.*, 1991; Coupeau, 2011). GaHV-2 is classified as an *Alphaherpesvirinae* regarding DNA sequence homology and genome organization. (Lee *et al.*, 2000a). However, the biological properties of GaHV-2 are more akin to those of *Gammaherpesvirinae* such as the Epstein-Barr virus (EBV) or the Kaposi's sarcoma herpesvirus (KSHV) (Nair & Kung, 2004).

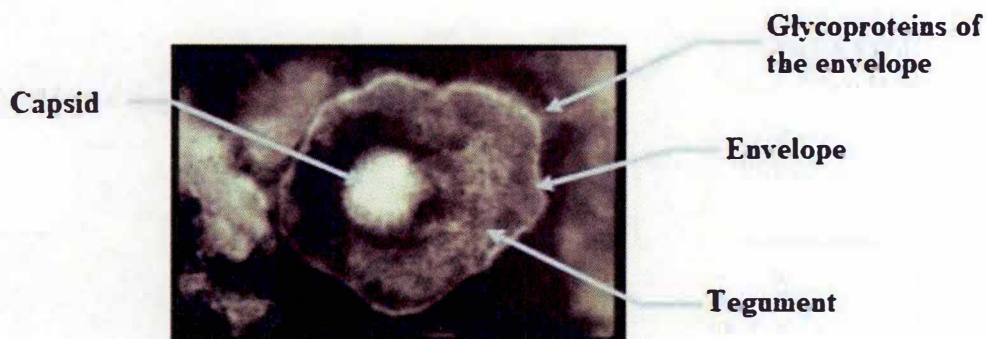

Figure 3: View of a GaHV-2 viral particle with an electrical micrograph (picture of F. Coudert). The typical structure of the herpesviruses is visible: the capsid, the tegument and the envelope with its associated glycoproteins.

I.2.2. Historical context:

This disease was first described by the Hungarian veterinarian Jozef Marek in 1907 as a poultry paralysis. This disease is a lymphoproliferative disease characterized by a lymphoid infiltration in the peripheral nerves and development of tumors in visceral organs, muscles and skin (Nazerian, 1973). Before the 1960s the Marek's disease did not have a profound impact on the poultry industry. In the 1960s, the disease became more severe along with the intensification of the poultry industry. This led to the rise of the acute form of the disease. This acute form is highly virulent, induces rapidly tumors and shows a mortality rate until 60% (Witter & Schat, 2003). In 1968, the two scientists Churchill and Biggs have isolated the GaHV-2 virus from tumors of infected chickens (Churchill & Biggs, 1968). The first vaccine against the Marek's disease was developed shortly after this identification (Churchill, 1969). Massive vaccination enabled the control and the stabilization of the economic impact of the disease on poultry industry. But in the end of 20th century, several highly virulent strains appeared and were shown a resistance to be able to escape vaccination (Witter, 1997).

I.2.3. Vaccination of the Marek's disease:

The first vaccine was based on the HPRS-16 oncogenic strain of the GaHV-2 that was attenuated (Churchill *et al.*, 1969). Soon after this first vaccine, the HVT (Herpesvirus of turkey) vaccine was developed based on the non-oncogenic serotype 3 (*Meleagrid herpesvirus 1*) that infects turkeys (Okazaki *et al.*, 1970). In 1973, the CVI988/Rispens vaccine was licensed in several European countries. This vaccine is composed by a low pathogenicity strain of the serotype 1 (GaHV-2) (Rispens *et al.*, 1972). The HVT and the CVI988/Rispens vaccines show similar levels of protection in several studies (Maas *et al.*, 1982). Following the rise of highly

virulent strains of GaHV-2, the CVI988/Rispens vaccine showed a higher protection than the HVT vaccine against these highly virulent strains (Witter *et al.*, 1995). In 1978, the non-oncogenic strain SB-1 that belongs to the serotype 2 (GaHV-3) was characterized by Schat and Calnek team (Schat & Calnek, 1978). It was shown that a bivalent vaccine composed by the combination of the SB-1 and the HVT vaccines provides a high protection against the MDV infection (Calnek *et al.*, 1978). As said before, all the developed vaccines protect chickens from a rapid death but they don't avoid the infection and the transmission of the virus. Thus, the selection against the virulence is reduced and lead to the apparition of viral strains with a higher virulence (Atkins *et al.*, 2013; Read *et al.*, 2015).

I.2.4. Clinical forms of the Marek's disease virus:

Two clinical forms of the Marek's disease have been identified: the classical and the acute form. The first one begins progressively following an incubation time of three to nine weeks. The infected chickens progressively suffer of paralysis following the infiltration of lymphoid cells in the peripheral nerves. The symptoms are essentially motility problems at disease onset and later troubles such as dangling wings, respiratory difficulties are observed. Chickens finally die of starvation because they cannot eat anymore (Davison & Nair, 2004).

With the acute form of the Marek's disease, chickens die within only four weeks post infection. Chickens suffer of anemia, paralysis and animals are thinner. In difference with the classical form of the disease, chickens with the acute form develop tumors on several visceral organs. Indeed, solid tumors can be observed in the skin, lungs, kidneys, spleen, liver, heart, reproductive organs. In addition, nodules might be present at the basis of feather (Coupeau, 2011).

As said before, the *Mardivirus* genus is divided in three viral species where only GaHV-2 contained oncogenic pathotypes. Indeed, there are four pathotypes: mildly virulent (m), virulent (v), hypervirulent (vv) and hyper-hypervirulent (vv+). It was shown that the oncogenicity increases with the virulence of the strain (Witter, 1997) (**Table 1**). The RB1B strain of GaHV-2 that is used in this master thesis is part of the hypervirulent (vv) pathotype.

Table 1: Classification within the *Mardivirus* genus. For each viral species, the pathotypes are shown and the level of oncogenicity. For each pathotype, some strains of the virus are presented. The RB1B strain used in this master thesis is part of the hypervirulent (vv) pathotype of GaHV-2.

Viral species	Pathotype	Oncogenicity	Strains
GaHV-2 (MDV-1)	Hyper hypervirulent (vv+)	+++	RK1, 584A, 648A
	Hypervirulent (vv)	++	RB-1B, Md-5, Md-11
	Virulent (v)	+	GA, HPRS16, JM
	Moderate (m)	No	Rispens, Cu-2, HPRS17
GaHV-3 (MDV-2)	Moderate (m)	No	SB-1, HPRS24, HN-1
MeHV (MDV-3)	Moderate (m)	No	HVT, WTHV, HPRS26

I.2.5. Physio-pathology of the Marek's disease virus:

The chicken infection with GaHV-2 begins by inhalation of contaminated dust or feathers follicles. So, the virus infects chickens through the respiratory tract where GaHV-2 begins its viral cycle. This cycle occurs through four phases which are the early productive phase, the latency phase, the late productive phase and the tumoral phase (**Fig. 4**) (Baigent & Davison, 2002).

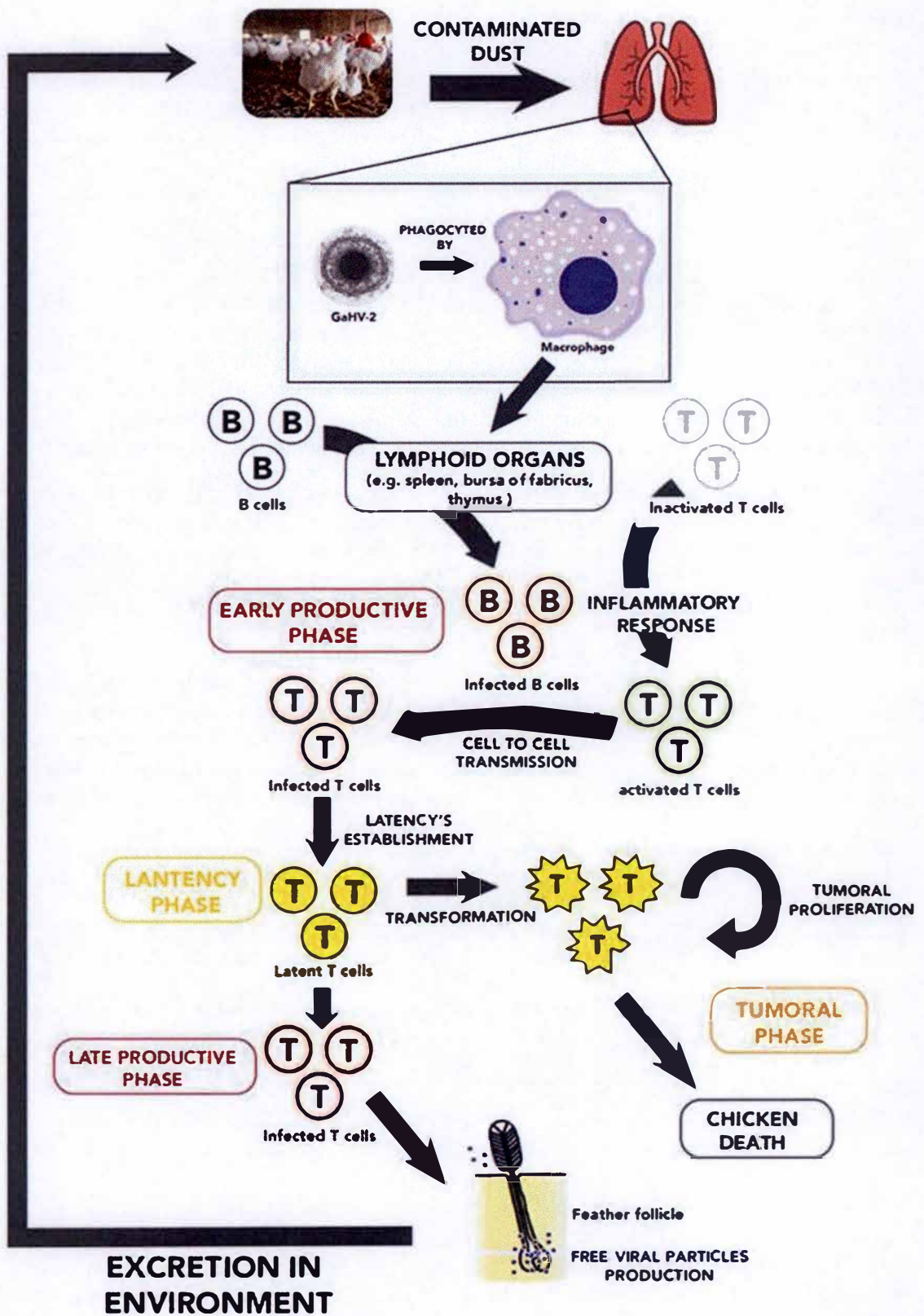

Figure 4: Representation of the viral cycle of GaHV-2 in chicken. This viral cycle begins with the inhalation of viral particles by the chicken and finish by the death of the host and the dissemination of free viral particles.

I.3.5.1. The early productive phase:

In this phase, GaHV-2 particles are phagocytosed by macrophages and dendritic cells present in the lungs (Barrow *et al.*, 2003). These cells brought GaHV-2 to lymphoid organs between 24 and 36 hours post-infection (pi) (Schat & Nair, 2008b). The early productive phase occurs in these organs, preferentially in the spleen and concern essentially the B cells. In B lymphocytes, GaHV-2 replicates and is transmitted to adjacent B and T lymphocyte. This phase occurs between the days 3 and 6 pi. At the end of this step, the virus enters in latency phase mainly in infected T lymphocytes of the CD4⁺ lineage (Baigent & Davison, 2002) (Fig.4).

I.3.5.2. The latency phase:

This second phase begins at 6 or 7 days pi and consists in the integration of the viral genome mainly in TCD4⁺ cells genome. The establishment and the maintenance of latency requires the expression of several viral and cellular genes. The viral ones are *LAT*, *meq* gene. At the cellular level, factors such as the latency maintaining factor (LMF), interferons- α / γ (IFN- α / γ) and nitric oxide (NO) are able to trigger an inhibition of the viral replication. (Levy *et al.*, 2003; Coupeau, 2011) (Fig.4).

I.3.5.3. The late productive phase:

After 2 to 3 weeks pi, GaHV-2 might reactivate in some latently infected cells. During this step, neo-viral particles are produced and disseminate from cell to cell. This reactivation occurs in lymphoid organs and in several tissues, such as the kidneys, the liver and the skin. During this phase, GaHV-2 replicates also in feather follicles keratinocytes. The feather follicles are the unique production site of free viral particles and promotes the horizontal transmission of the virus (Calnek *et al.*, 1970) (Fig.4).

I.3.5.4. The tumoral phase:

This last phase is specific to the oncogenic strains of GaHV-2 and appears from 3 weeks pi. This phase is characterised by the progressive transformation of latently infected CD4⁺ T cells. This transformation leads to the formation of T lymphoma in several organs (Cauchy & Mazzella, 1971) (Fig.4). During transformation, several viral and cellular proto-oncogenes are highly expressed. For instance, the lymphoma induced by GaHV-2 express the CD30 antigen that are also expresses in lymphomas induced by other herpesviruses such as EBV (Burgess *et al.*, 2004). Another hallmark of GaHV-2 lymphoma is the strong inhibition of tumor suppressor gene expression. For example, there is a down-expression of several host miRNAs known as tumor suppressors such as miR-126, miR-150 and miR-223. These common characteristics made of GaHV-2 a good animal model for the study of lymphomagenesis induced by a herpesvirus.

Several GaHV-2 genes play an essential role in the apparition of lymphoma during the tumoral phase. The principal oncogene of GaHV-2 is the *meq* gene that is the most consistently expressed latency gene (Parcells *et al.*, 2001). This gene encodes for a 339 amino-acid protein that is characterized by an N-terminal Bzip domain and a proline-rich C-terminal transactivation domain (Jones & Kung, 1992). Meq can dimerize with several partners such as itself, c-Jun, Jun-B, ATF2 and Fos. These dimerization lead to the apparition of active transcription factors involved in the tumorigenesis phenomenon.

Besides the *meq* gene, another gene involved in the GaHV-2 oncogenesis is the viral telomerase RNA (vTR). This vTR molecule associates with the chicken telomerase reverse transcriptase (chTERT) and increases the activity of the telomerase activity in infected chickens (Trapp *et al.*, 2006). It has been shown that vTR is overexpressed in transformed T-cells,

showing its role in the tumorigenesis. In fact, vTR deleted strains are strongly attenuated *in vivo* (Trapp *et al*, 2006).

I.3. MicroRNAs (miRNAs):

I.3.1. General informations:

In 1993, the first miRNA (*lin-4*) was described in the *Caenorhabditis elegans* (*C. elegans*) nematode (Lee *et al*, 1993; Almeida *et al*, 2011). But, the first mechanism of RNA interference (RNAi) was characterized later on 1998 in the same model (Fire *et al*, 1998). Since a few years, a lot of research were done on miRNAs. These short single stranded RNA sequences of 19-22 nucleotides can actually control the expression of their targets genes at the post-transcriptional level. This regulation occurs by the binding of the miRNA to its targets messenger RNA (mRNA). Depending on the degrees of matching, the mRNA is degraded or its translation is inhibited (Meister & Schmidt, 2010). In the context of some pathologies such as cancers and diabetes, miRNAs are well studied. Indeed, a misexpression of several miRNAs is associated with the development of these pathologies. Thus, a greater understanding of the interactions of miRNAs and their potential targets may lead to the development of new therapies and new diagnostic tools.

I.3.2. Biosynthesis of miRNA:

The synthesis of miRNAs begins with the transcription of the miRNA sequence mainly by the RNA polymerase II. A primary-microRNA (pri-miRNA) is then expressed and shows a hairpin structure (**Fig. 5.A**). This pri-miRNA is then cleaved by the Drosha enzyme (Type III RNase) and its cofactor, DGCR8. The cleaved pri-miRNA leads to the production of a precursor-microRNA (pre-miRNA) (**Fig. 5.B**). This pre-miRNA is then exported to the cytoplasm through the exportin 5 protein. In cytoplasm, the hairpin structure of the pre-miRNA is further cleaved by the Dicer enzyme (Type III RNase) to generate a double stranded miRNA (**Fig. 5.C**). This double stranded miRNA is loaded into the RISC (RNA-Induced Silencing Complex) complex. During this loading, the two strands are separated by the helicase activity of the RISC complex. Then this complex conserves the steadiest strand of the duplex to have the mature form of the miRNA (**Fig. 5.D**). Finally, this mature miRNA can regulate the expression of its target mRNAs by degradation or by the inhibition of the translation (**Fig. 5.E**) (Meister & Schmidt, 2010).

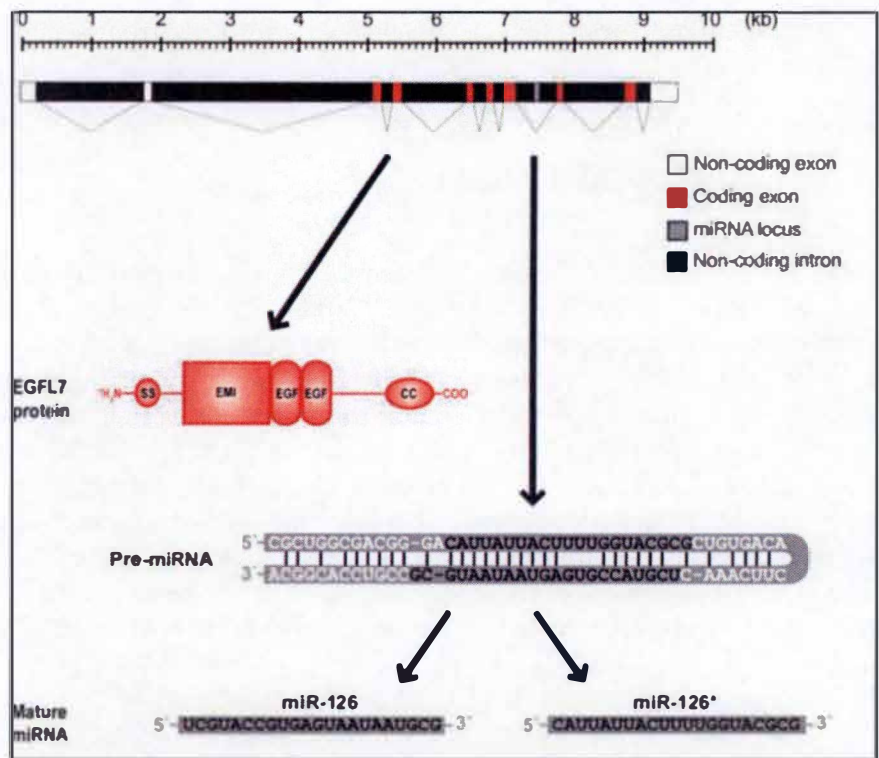

Figure 6: Human *EGFL7* gene organization. The *EGFL7* gene is composed by ten exons (three are non-coding). The transcription of the gene lead to the expression of the mRNA encoded for the EGFL7 protein and the pre-miR-126 (Meister & Schmidt, 2010).

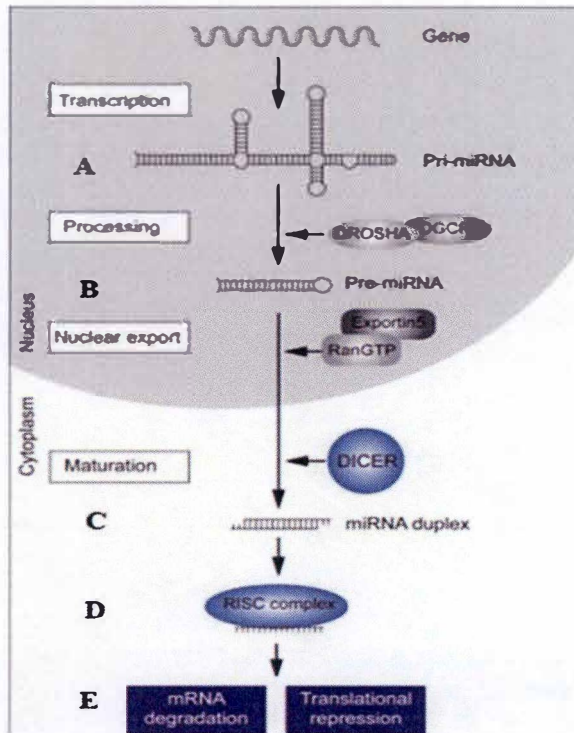

Figure 5: Biosynthesis of miRNAs. (A) The transcription of the miRNA sequence leads to the expression of the pri-miRNA. (B) Then its processed by DROSHA (type III RNase) into the pre-miRNA. DGCR8 is the cofactor of the reaction. (C) The pre-miR newly created is then exported out of the nucleus by the Exportin 5. In cytoplasm, the pre-miR is matured by the DICER RNase into a miRNA duplex. (D) The steadiest strand of the duplex is maintained by the RISC complex to form the mature miRNA. (E) The mature miRNA is responsible of the inhibition of the translation or of the degradation of its targets mRNAs. (Meister and Schmidt, 2010).

I.4. The miR-126:

This master thesis focused on miR-126, a host miRNA that has been shown to be repressed during the GaHV-2 tumorigenesis phase. The premiR-126 sequence is located into the 7th intron of the Epidermal growth factor-like protein 7 (EGFL7) gene in vertebrates (Meister & Schmidt, 2010).

I.4.1. The host gene of miR-126, EGFL7:

The Epidermal growth factor-like 7 (EGFL7) gene was identified to be the gene host of the miR-126. In vertebrate, this gene is composed by ten exons. The pre-miR-126 sequence is included within the seventh exon of this gene (Fig. 6) (Meister & Schmidt, 2010). The EGFL7 protein is associated with the blood vessels development and maturation during vertebrate embryogenesis. Indeed, EGFL7 ensures the migration and the adhesion of endothelial cells beside themselves to form newly blood vessels. Furthermore, EGFL7 expression is maintained in several tissues in the adult organism such as in highly vascularized organs, during menstruations in the endometrium or it is associated with the tumoral angiogenesis (Meister & Schmidt, 2010). This protein possesses several distinct domains such as a secretion signal peptide, an Emilin-like domain (EMI), two EGFL-like (EGF) domains and a liaison domain to Ca^{2+} ions (Fig. 6) (Meister and Schmidt, 2010).

I.4.2. Importance of miR-126:

Both EGFL7 protein and the miR-126 play a role in the angiogenesis process during the embryogenesis. Through an *in vivo* context, Kunhert and its collaborators have been tested the

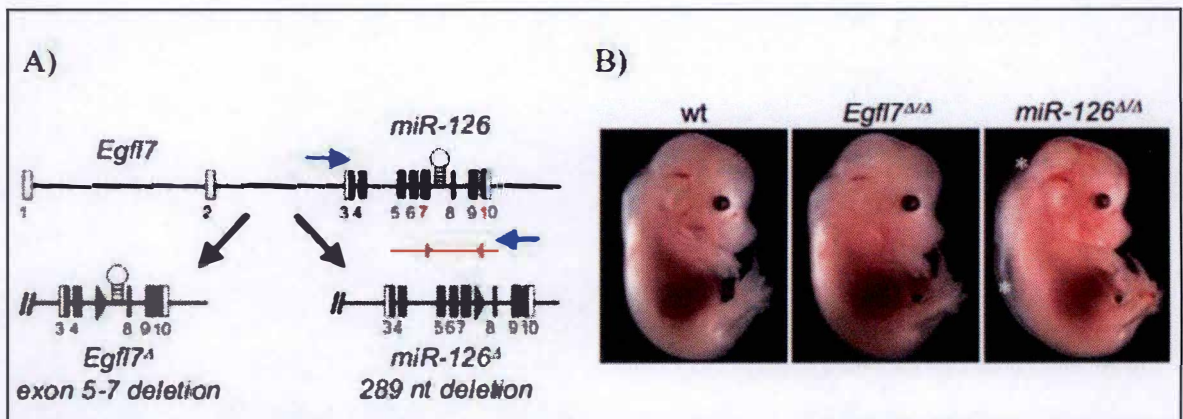

Figure 7: Development of two mice K.O. mutants for EGFL7 and miR-126. A) Mutants for EGFL7 present a deletion of the exons 5, 6 and 7 while miR-126 mutants were produced by excision of the 7th exon. The loxP excision system was used to generate these mutants. B) Both mutant embryos were compared to the wt embryos. Edema are visible for the miR-126 K.O. (*miR-126^{Δ/Δ}*) while EGFL7 K.O. (*Egfl7^{Δ/Δ}*) show a similar phenotype with the wild-type (wt).

degree of participation of these two partners in angiogenesis. To do this, two conditions of mice were developed by the loxP deletional method, a EGFL7 K.O. (*Egfl7^{Δ/Δ}*) and a miR-126 K.O. (*miR-126^{Δ/Δ}*) group (Fig. 7.A.). Embryos with the *Egfl7^{Δ/Δ}* mutation show a better survival rate than mice of the *miR-126^{Δ/Δ}* group. Indeed, the miR-126 deletion, lead to edema formation because blood vessels are not well formed and are pervious (Fig. 7.B.). The principal observation of this experiment is the angiogenesis defect in the miR-126 deletant group while the *Egfl7* deletant one seems to have a normal angiogenesis. Finally, this experiment brings to light the importance of the miR-126 in the angiogenesis process (Kunhert *et al.*, 2008).

I.4.3. Functions of miR-126:

As mentioned above, miR-126 is mainly expressed in endothelial cells and participates to the angiogenesis process. Indeed, this miRNA targets some mRNAs encoded for protein involved in angiogenesis repression. Thus, when miR-126 is expressed, it targets some mRNAs to remove the angiogenesis repression. To do this, it targets mRNAs such as the Sprouty-related EBH1 domain containing protein 1 (SPRED1), the p85 β regulatory subunit of the Phosphatidylinositide 3-Kinase (PI3K). Both proteins negatively regulate the Vascular Endothelial Growth Factor (VEGF) pathway by inhibition of the ligation of this factor with the VEGF receptor (Guo *et al.*, 2008).

Beside the important role of miR-126 in the angiogenesis, it seems to be a tumor suppressor by targeting several mRNAs encoded for proto-oncogenes. Indeed, several studies bring the light to this function (Guo *et al.*, 2008; Li *et al.*, 2014; Zhang *et al.*, 2008; Li *et al.*, 2010).

I.4.4. MiR-126 as tumor suppressor:

As said before, in the case of several human cancers, the miR-126-3p is down-expressed. In this context, some miR-126 target genes were identified. One of this target is the regulatory p85 β subunit of PI3K protein which plays an essential role in cell proliferation and survival. Studies performed in the context of colon cancer showed that miR-126 is repressed in colon adenocarcinoma. This down-regulation increases the tumorigenesis in colon cells by a loss of the PI3K protein inhibition. (Guo *et al.* 2008; Li *et al.*, 2010).

Thanks to studies working on the breast cancer, the Insulin-like growth factor 1 (IRS-1) protein seems to be targeted by the miR-126. IRS-1 is activated by liaison with the Insulin Growth Factor-1 (IGF-1) and activates the PI3K (Zhang *et al.*, 2008). Thus, IRS-1 is involved in cell survival and proliferation beside PI3K. By targeting two keys proteins involving in proliferation and survival pathways miR-126 increase its tumor suppressive function.

A study on stomach cancer has been shown a target of miR-126 in this cancer, the CT10 Regulator of Kinase (Crk). Crk is an adaptor protein involved in the transduction of signal following an activation of tyrosine-kinases sensitive to growth factor. Indeed, when Crk is activated, it participates in the cellular proliferation. Activation of Crk lead to the loss of E-cadherin involved in cell adhesion. Thus, miR-126 by its regulation of Crk can negatively act on two ways to develop cancers (proliferation and motility). When miR-126 is overexpressed in gastric cancer cells, a inhibition of Crk expression is observed and can be correlated with the loss of motility in matrigel tests (Li *et al.*, 2014).

I.5. The recombinant virus technology:

The main step of this master thesis was the creation of a recombinant virus of GaHV-2. Since few years, several pieces of research on GaHV-2 used the recombinant virus technology to develop mutated version of the GaHV-2 to study the biological functions of viral genes involved either in replication, in latency or in tumorigenesis. The aim of this technology is to create GaHV-2 mutated version to study the biological properties of these mutations in an *in vivo* context. The concept of GaHV-2 recombinant virus is feasible thanks to the creation of the first bacterial artificial chromosome (BAC). Indeed, in 1997 the cytomegalovirus genome was cloned as a BAC that easily allows the site targeted mutagenesis and the replication in *Escherichia coli* (*E. coli*) (Messerle *et al*, 1997). The first GaHV-2 genome was cloned in a BAC in 2000 by Schumacher and collaborators team (Schumacher *et al.*, 2007). In 2003, the hypervirulent RB1B genome, that we study in this master thesis, was cloned as a BAC by the introduction of the BAC cassette (Petherbridge *et al*, 2003). The apparition of GaHV-2 BACs revolutionized the way to study the infection and the tumorigenesis of this herpesvirus. Indeed, these BACs show several advantages such as genetic stability while it is maintained in *E. coli* through the mini-F plasmid. In addition, these GaHV-2 BAC might be modified by the powerful recombination machinery of *E. coli* (Brune *et al*, 2000). So, through the action of recombination system such as the RED one, GaHV-2 BACs can easily be modified within particular *E. coli* strains to delete specific GaHV-2 genes, to modify genetic capacity (point mutations) or to integrate foreign genetic sequences.

After the creation of GaHV-2 BACs, several recombinant viruses were investigated. For now, most recombinant viruses that have been generated, carried a deletion of a particular viral locus. Indeed, deletion of several GaHV-2 genes enabled to know whether this gene is essential for viral infection, replication, maintenance or viral induced oncogenesis. For instance, recombinant viruses with deleted *vTR* and *meq* genes have led to the better comprehension of their roles during GaHV-2 infection (Trapp *et al*, 2006).

I.6. Aim of the project:

In the context of the lymphomagenesis induced by the Marek's disease virus, this master thesis aims to provide a better understanding of the relation between the development of tumors related with the latency phase of GaHV-2 and the down-regulation of the cellular *gga*-(*gallus gallus*) miRNA-126. To address this question, a recombinant virus of the hypervirulent (vv) RB1B strain of GaHV-2 will be developed. To generate this virus, a *gga*-miRNA-126 expression system will be integrated into the RB1B genome by insertional mutagenesis based on the bacmid DNA of the virus that can easily be maintained, transformed and amplified in bacteria. In parallel, a control recombinant virus containing a mutated version of *gga*-miR-126 will be developed. The *gga*-miR-126 expression cassette will be inserted between the US2 gene and the BAC cassette of the RB1B BAC (Fig. 8). US2 gene is part of the Unique Short (US) region of the GaHV-2 genome and encodes for a non-essential protein of the viral tegument. The BAC cassette has been artificially inserted into the RB1B genome and disrupts the non-essential US2 gene.

After this, the recombinant viruses will be reconstituted by transfecting chicken embryo fibroblasts (CEF). The recombinant viruses will be amplified in order to produce inoculum for *in vivo* trials. In order to characterize the recombinant viruses, their biological properties will

be assessed *in vitro*. First, viral titers will be determined to generate inoculum with the equivalent viral loads to infect sensitives chickens. Secondly, miR-126 expression will be checked after serial passages of the viral infection in CEFs culture. Indeed, it is essential to characterize the functionality of the miR-126 expression system that was developed. The final aim of this project is to setup a system of *in vivo* miR-126 restoration in a lymphomagenesis model where this miRNA expression is lost.

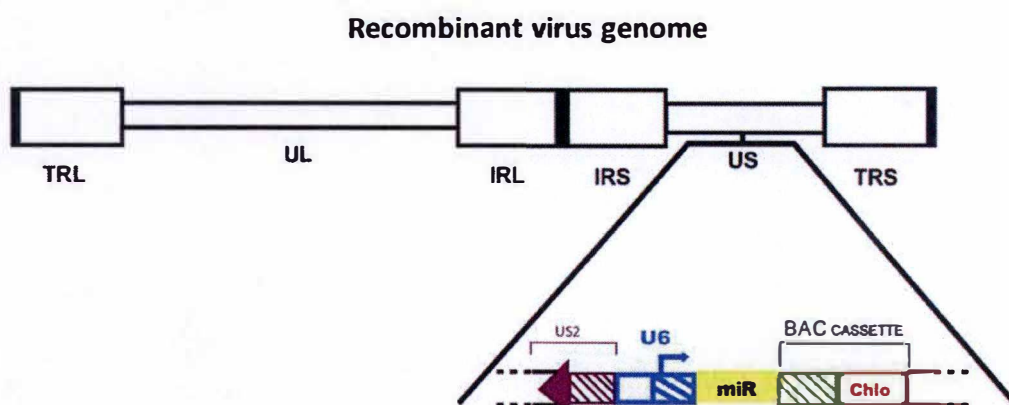

Figure 8: Presentation of the genome structure of the recombinant virus RB1B strain of GaHV-2 containing a miR-126 expression cassette. Genome of RB1B strain constituted by a unique long (UL) region and a unique short (US) region. These regions are boarded respectively by a Terminal Repeat Long (TRL) and Internal Repeat Long (IRL) or Internal Repeat Short (IRS) and Terminal Repeat Short (TRS). The miRNA expression system (U6+miR) is inserted in US region between US2 and BAC cassette. The promotor controlling the constitutive expression of the chicken U6 RNA is displayed in blue. The sequence of pre-miRNA is displayed in yellow. US2 and BAC cassette regions constituting the insertion sites are respectively displayed in purple and green. The BAC cassette contains a resistance gene to Chloramphenicol. This resistance gene is displayed in red (*cat* gene).

This master thesis is included in a project trying to understand the molecular regulations and functions of the cellular gga-miR-126 during tumorigenesis induced by GaHV-2. Previous research in the host lab was performed on the transcriptional regulation mechanisms of gga-miR-126. Samples were harvested from *in vivo* and *in vitro* samples representing the different viral cycle phases. This was done in order to assess if in GaHV-2 induced tumorigenesis, the gga-miR-126 was repressed. Results showed that this miRNA is repressed during tumorigenesis. Thereafter, this repression was characterized by the study of DNA methylation pattern in two regions rich in CpG islands potentially controlling gga-miR-126 expression. It was observed that repression was due to a higher percentage of methylation in the gga-miR126 region.

Moreover, functionality of gga-miR-126 is studied in GaHV-2 induced tumorigenesis on an *in vitro* context. A stable cell line was developed in the host lab allowing the inducible overexpression of gga-miR-126 after adding Tetracyclin. These cells are called MSB-1 and they are typical lymphoblast cell line infected by GaHV-2 infection. Phenotypical analysis and apoptotic markers will be studied.

In parallel of this project, bioinformatic analysis were assessed to identify the potential targets of the gga-miR-126 strand 3p. The firsts potential targets mRNAs encoded for the CT10 regulator of kinase (CRK), the Transient potential cation channel 6 (TRPC6), the Telomere maintenance 2 (TELO2) and the Sprouty-related, EVH1 domain-containing protein 1 (SPRED1) proteins. Preliminary luciferase assays were performed on Baby Hamster Kidney-21 (BHK-21) cell line.

II. Material and methods:

II.1. Cellular cultures methods:

II.1.1. Primary CEF culture:

To amplify our recombinant virus, Chicken Embryo Fibroblasts (CEFs) must be harvested. To create a primary CEF culture, cells were removed from chicken's embryos. For insure sterility we have working within vertical laminar flow. Fertilized eggs were incubated to day 12. At day 12, the extraction of CEF was realized. First, an opening was created at the round side of eggs with a dissection scissor. By this opening, embryos were extracted out of the eggs. Then embryos were put in petri dishes with DPBS (Dulbecco's Phosphate-Buffered Saline). Immediately, the head, wings and legs of embryos were cut. Feathers and organs were removed too. The rest of abdomen was next transferred to another petri dish with new DPBS. In this new petri dish, the abdomen is cut into little pieces. These pieces were filtered and then were put in a 50ml falcon with 2,5ml of trypsin (10X). Then the falcon was shake for 5 min. Next this time, the pellet must decant. Then, the supernatant was recovered and put in a new 50ml falcon with fresh 2,5ml trypsin. This tube was also shake for 5 min. The pellet must decant too and then this second supernatant is put in 10 ml of DMEM primary CEF media in a 15ml tube. The primary media is Gibco® DMEM (Dulbecco's Modified Eagle Medium) complemented with 2,5 % FBS (Fetal Bovine Serum), 1,25% CS (Chicken Serum), 1% Penicillin/Streptomycin (10µg/µl), 1% Amphotericin B (2,5µg/ml) and 1% Tryptose Phosphate (1,475 g/L). Then, cells were pelleted by centrifugation with 400g over 10 min at room temperature. After centrifugation, the supernatant was thrown away and the pelleted cells were resuspended in 10 ml of fresh media. Finally, cells were counted by a Neubauer cell to have 7. 10⁶ cells per F75 (Flask of 75 cm²).

II.1.2. Secondary CEF culture:

Between 4 to 7 days next the establishment of primary CEF culture, secondary CEF culture can be realized. First, the media of the primary CEF culture was removed. Then PBS/EDTA was added in F75 to prepare the cells before the addition of 1 ml of trypsin during maximum 3 minutes. Trypsin was previously warmed up to 40,5°C. When the cells are not stuck on plastic, cells were flushed and put in a 50ml tube. The clustered cells were pelleted by a centrifugation of 300g over 7 minutes at room temperature. After centrifugation, the supernatant was thrown away and the pelleted cells were resuspended in 10 ml of fresh secondary DMEM media. The secondary media is Gibco® DMEM complemented with 1 % FBS, 0,5% Chicken Serum, 1% Penicillin/Streptomycin (10µg/µl), 1% Amphotericin B (2,5µg/ml) and 1% Tryptose Phosphate (1,475g/L).

Cells were counted by a Neubauer cell to have 50. 10⁴ cells per P6 well for a final volume of 2ml. For a F25 (Flask of 25cm²), 50. 10⁴ cells were needed for a final volume of 5ml. For a F75, 1,5.10⁶ cells were needed in a final volume of 20 ml.

II.2. Vectors:

II.2.1. The pepKanS2 plasmid:

The pepKan-S2 was created by Tischer's team in 2006. This plasmid was created by addition of a resistance gene to Kanamycin (*aphA-I* gene) boarded by two restriction sites of

Sce-I enzyme into pcDNA3 plasmid. Moreover, this KanR cassette was integrated in the pcDNA3 at the restriction sites of BglII and NruI (Tischer et al., 2006) (Fig. 9).

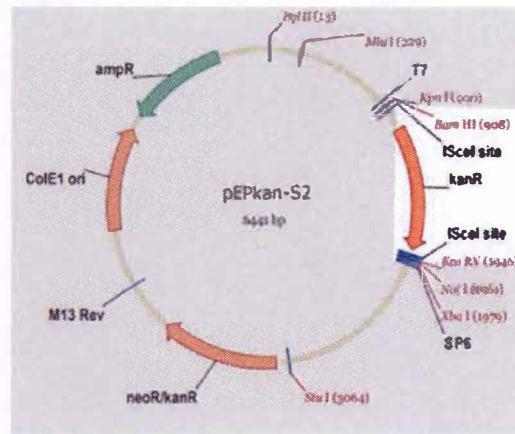

Figure 9: Representation of the pepKan-S2 plasmid. The selected region of the pepKanS2 (6441 bp) is the Kanamycin resistance gene (Kan^R) and the two boarded SceI restriction sites (ISceI site). This resistance cassette (1000bp) was used for the selection of clones that have well integrated the miRNA expression cassette inside the GaHV-2 genome.

II.2.2. The pRB1B-5 bacmid:

This bacmid derives from the initial pRB1B bacmid of the GaHV-2 develop, by insertion of mini-F vector inside US2 gene (Schumacher *et al.*, 2000). The pRB1B bacmid was developed by a team of IAH (Institute of Animal Health, Compton, Berkshire, England). To do this, the pDS-pHA1 (BAC cassette) plasmid was integrated in the pRB1B bacmid. Moreover, the pDS-pHA1 (7.2 Kbp) contained a resistance gene to Chloramphenicol (*cat* gene-Chloramphenicol Acetyl Transferase), the pHA1 plasmid and the *gpt* gene encodes for the Guanine Phosphoribosyl Transferase. The insertion of this BAC cassette was performed by homologous regions of 2Kbp and 3Kbp boarded the US2 gene of the vvRB1B strain of GaHV-2 (Petherbridge *et al.*, 2003) (Fig. 10).

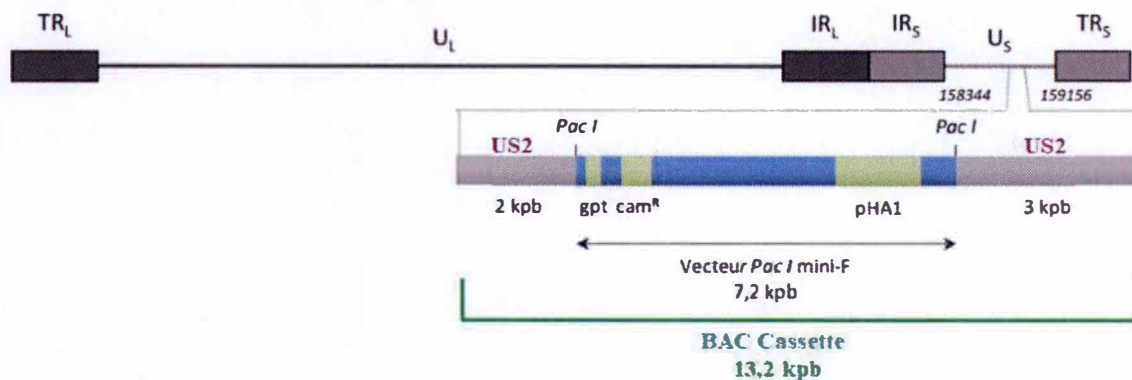

Figure 10: Representation of the pRB1B-5 bacmid. The RB1B genome is cloned as bacterial artificial chromosome (BAC). The BAC cassette (13.2 kbp) disrupted the US2 gene located in the unique short (US) region. This cassette is composed by two homologous regions (US2) of 2.0 Kb and 3.0 Kb with the US2 gene. This cassette also contains the pDS-pHA1 plasmid also called the PacI/miniF vector (Vecteur Pac I mini-F). This PacI/mini-F vector contains the gene of guanine phosphoribosyl transferase (*gpt*), the pHA1 plasmid (*pHA1*) and a resistance gene to chloramphenicol (*Cam^R*). This Bac Cassette is inserted between 158344 and 159156 bp of the viral genome.

II.2.3. Promega PGEM®-T Easy plasmid and TA cloning:

PGEM®-T Easy (Promega) was used for direct TA cloning of PCR product. This plasmid was digested by the EcoRV enzyme. After chemical addition of protruding thymidine at both 5' ends, the vector is adapted for ligation of PCR products obtained with Taq polymerase that provides a 3' Adenine overhang at the end of PCR amplicons. This plasmid of 3000 bp carry the LacZ cassette available for white-blue tests. Finally, this plasmid contains the gene resistance to Ampicillin (*bla* gene-Beta-lactamase) (Fig. 11).

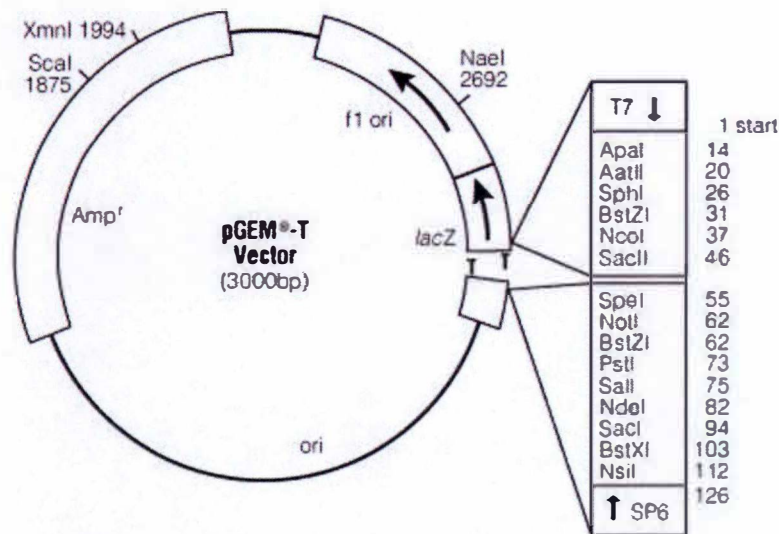

Figure 11: Representation of the pGEM®-T plasmid. The pGEM-T plasmid (3Kbp) possesses free thymine extremities for TA cloning of PCR products. This plasmid contains a lacZ cassette (*lacZ*) for white-blue tests. The resistance gene to ampicillin (**Amp^R**) is also carried by the plasmid. This plasmid also carries the f1 origin of replication (**f1 ori**).

II.3. Bacteria strains:

II.3.1. DH10B strain of E. coli:

This strain is a derivative of the K12 strain of *E. coli*. This strain is principally used for its ability to carry large plasmids. Indeed, this strain was carried all the plasmid construction in the creation process of the miR-126 expression cassette. This strain is also auxotrophic to leucine.

II.3.2. GS-1783 strain of E. coli:

This strain was developed from DH10B strain of *E. coli*. These bacteria carry the genome of GaHV-2 strain pRB1B-5 bacmid. They are genetically modified to bear in their genome two inducible promoters. First, a thermo-inducible promoter that expresses the RED system of homologous recombination. Secondly, a promoter inducible by L-Arabinose that expresses the Sce-I enzyme (Tischer *et al.*, 2010).

II.4. Molecular methods:

II.4.1.High-fidelity amplification by NEB Q5® :

To insure fidelity of the PCR products amplification, the NEB Q5® Hot Start High-Fidelity DNA polymerase was used. PCR using NEB Q5® were performed as follow. The PCR mix (50µl) contained 10 µl of Q5® reaction buffer 5X, 1µl of dNTP (10 mM), 2.5µl of each primer (10µM) (forward and reverse), 0.5 µl of Q5 polymerase (1U) and the appropriate volume of water to reach a total volume of 48µl. At this mix, 2µl of DNA template (from 0,5ng for plasmid DNA to 200ng for genomic DNA) were added. For negative control, 2µl of water were added.

II.4.2.DNA digestion catalyzed by restriction enzymes (HpaI, NheI, KpnI):

To digest restriction sites, present on DNA, a restriction mix was performed. 20 µl of DNA (10µg) were added in a restriction mix. This mix was composed by 5µl of NEB cutsmart® buffer 10X, 2µl of enzyme (NEB HpaI®, KpnI®, NheI®-200U), 23µl of water to form a final volume of 50µl. The mix was incubated 1h30 at 37° C to start the digestion. Finally, restriction products were put on agarose gel with Nippongenetics™ Midori Green Advance® in order to check the efficacy of the reaction.

II.4.3.Purification on gel:

To recover sequences of interest following a gel migration after any restriction reaction or PCR amplification, the Nucleospin® Gel and PCR Clean-up kit (Macherey-Nagel™) was used to purify the DNA band of interest. The part of agarose gel containing the DNA was cut and incubated with NTI buffer (200µl per 100µg). The solution was incubated for 10 minutes at 50°C to dissolve the gel. After that, the solution containing DNA was loaded on purification columns. DNAs was fixed to the column by centrifugation at 11 000 g for 30 seconds. The eluted solution was thrown away. This step was repeated until all the solution was passed on the column. Then 2 washes were realized by adding the NT3 (+ Ethanol 100%) Buffer and by centrifugation at 11 000g for 30 seconds. After washes, the column was dried by a centrifugation at 11 000g for 1 minute. Finally, DNA was eluted in a new Eppendorf tube by adding 50µl of water and by a final centrifugation at 11 000g for 1 minute.

II.4.4.Dephosphorylation of digested plasmids:

After the gel purification of a restricted plasmid, the linearized vector was dephosphorylated to avoid recircularization. The eluted plasmid from gel purification was added in a dephosphorylation mix. This mix was composed by 10µl of NEB cutsmart® buffer 10X, 35µl of water and 5µl of NEB Calf Intestinal Phosphatase (CIP®-50U). The reaction was performed in a final volume of 100µl. This mix was incubated for 20 minutes at 37°C. After this first incubation, 4µl of CIP were newly added at the mix and it was incubated for an additional 20 minutes period at 37°C. Finally, the reaction was stopped by an incubation at 65°C for 20 minutes.

II.4.5.Plasmid purification by Phenol/Chloroform:

Following the dephosphorylation of restricted plasmids, a phenol/chloroform purification was realized. Because phenol/chloroform are volatile and toxic compounds, all the

manipulations for this purification were realized under a chemical hood. For the first step, the same volume of phenol/chloroform was added at the dephosphorylation mix. The phenol and chloroform act by the removal of proteins and lipids out the aqueous phase. The mix was then centrifugated at 16 000 g for 15 minutes. Following this step, the upper phase namely the aqueous phase, was collected since it contained the dephosphorylated plasmid. Next, an iso-volume of chloroform+ isoamyl alcohol (3-méthylbutan-1-ol) (49:1) was added to the aqueous phase. This step acts also by removal of proteins out aqueous phase. Isoamyl alcohol decreases superficial tension and facilitates separation of the phases. This new mix was centrifugated with the same conditions of the first centrifugation. The new aqueous phase was recovered for completing the purification. Three volumes of Ethanol 100% and 1/10 volume of sodium acetate 3M were added to the aqueous phase. This step allows plasmid precipitation. This solution was incubated 20 minutes at -80°C. Once defrozeed, the solution was centrifugated at 15 000 g for 10 minutes at 4°C. The supernatant was then discarded and 1 ml of ethanol 70% was added on the pellet. This last solution was centrifugated at 7500g for 10 minutes at room temperature. The obtained pellet was then resuspended in 100µl of water.

II.4.6.Ligation of PCR products (insert) into plasmids (vector):

Ligation of a restricted insert into a digested vector was performed by the NEB T4® DNA ligase. The ligation mix contained 5µl of NEB T4® buffer 2X, 1µl of the vector (digested and dephosphorylated), 3µl of the insert and 1µl of NEB T4® DNA ligase (400 U). Negative control was performed by replacing the insert with 3µl of water. The ligation reaction was performed over night at 12°C.

II.4.7.Electroporation of ligation products on DH10B strain of E. coli:

To this end, 1µl of ligation product was added on 50µl of electrocompetent bacteria. The electroporation was induced with 2500V for 5 milli-seconds in 2mm electroporation cuvette. The electroporated bacteria were incubated 1 hour at 37°C under agitation. After incubation, bacteria were spread on petri dishes with LB+Agar+Ampicillin (150µg/ml) to select bacteria bearing a pGEMT plasmid. A negative control by the electroporation of 1µl water was systematically performed. The petri dishes were incubated over night at 37°C.

II.4.8.PCR screening to detect positive colonies bearing the sequences of interest:

To screen bacteria, PCR mix was composed by: 4µl of 5X Green GoTaq® Reaction Buffer (Promega™), 0.44µl of dNTP (10mM), 1µl of forward and reverse primers (2µM), 0.07µl of GoTaq® DNA Polymerase (5 U/µl) (Promega™) and the appropriate volume of water to reach the final volume of 20µl of mix per PCR tube. After PCR reaction (30 cycles made of 30 seconds at 94° C, 30 seconds at appropriated T_m and 1 minute at 72°C) the different PCR products were placed on agarose gel.

II.4.9.Inducing of electrocompetence and RED system of GS-1783 strain:

The GS-1783 were pre-cultured in 20 mL of LB with 10µl of Chloramphenicol (50g/L). These pre-cultures were incubated over night at 32°C at 200 RPM. The next day, precultures

were diluted in 2YT and put at 32°C-200 RPM until optical density reached 0,45 (600nm). At $Do \approx 0,45$, the RED recombination system was induced by incubation of the culture at 42°C for 15 minutes under agitation. Then the culture was transferred in a bottle and was placed on ice for 45 minutes. After this time, three washings were made by addition of 200ml of cold ultra-pure water and centrifugation for 15 minutes at 5000 RPM at 4°C. After washings, the pellet was resuspended in 20 ml of sterile glycerol 10% and was centrifugated during 30 minutes at 4600 RPM at 4°C. The pelleted bacteria were then resuspended in 250µl of glycerol 10%. Finally, five aliquots of 50µl were made with this solution. These aliquots were used for the electroporation of transfer amplicons the same day of the production.

II.4.10. Restriction of the KanR cassette by induction of the Sce-I enzyme in GS-1783:

The selected clones of GS-1783 whose integrated our transfer amplicon on the bacmid RB1B were pre-cultured in 10 mL of LB with 10µl of Chloramphenicol (50g/L) and Kanamycin (50g/L). These pre-cultures were incubated over night at 32°C at 200 RPM. The next day, precultures were diluted in 2YT and put at 32°C-200 RPM until optical density reached 0,5 (600nm). At $Do \approx 0,5$, the same volume of 2YT+ L-Arabinose 2%+ Chloramphenicol were added to the culture to induce the expression of Sce-I enzyme. The induction of this enzyme was performed at 32°C for 1 hour at 200 RPM. Next, the cultures were incubated 15 minutes at 42°C under agitation to induce the RED system. After this time, the cultures were incubated for 2 hours at 32°C at 250 RPM. Finally, serial dilutions of 10^{-4} to 10^{-7} were realized. 150 µl of these dilutions were plated on petri dishes with LB+Agar+Chloramphenicol.

II.4.11. MidiPrep of High-copy plasmid or Low-copy plasmid:

To purify plasmids of interest in bacteria, midiprep's were done with the NucleoBond® Xtra (Macherey-Nagel™) plasmid purification kit. To do midiPreps, pre-cultures of bacteria colonies bearing our sequence of interest were done. For high-copy plasmid the bacteria were pre-cultured in 200 ml of LB with 200µl of each adequate antibiotic (Ampicillin, Chloramphenicol or Kanamycin) and were incubated over-night. For low-copy plasmid, a first pre-culture was done the morning in 5ml of LB with 5µl of the adequate antibiotic (Chloramphenicol, or both Chloramphenicol and Kanamycin). In the afternoon 2,5ml of the first preculture was added in 250ml of LB (X2). Then these 2 new pre-cultures were incubated over-night. The over-night temperatures and agitation for DH10B bearing pGEMTeasy are 37°C and 150 RPM. And for the GS-1783 bearing the RB1B bacmid these are 32°C and 200 RPM. The next day, the cultures were divided in 50ml tubes and then were centrifugated at 4.200 g. for 15 minutes at 4°C. The supernatant was then discarded and 8ml (high-copy) or 16ml (low-copy) of resuspension Buffer were added on the pellet of one tube. Then 8ml (high-copy) or 16ml (low-copy) of Lysis Buffer were added to the resuspension solution. This new solution was incubated 5 minutes at room temperatures. After that, 8ml (high-copy) and 16ml (low-copy) of neutralization buffer were added to stop the lysis. Next, the lysis residues were pelleted by a centrifugation of 4200g over 20 minutes and then the supernatant was loaded on NucleoBond® Xtra Column. In parallel the column was equilibrated with 12ml of Equilibration Buffer. After the loading, a first washing was done with 5ml of Equilibration buffer. After the washing, the filter was removed from the column. Then a second wash was done with 8ml of Wash Buffer direct on the column. The plasmid was then eluted in a new 50ml tube with the Elution Buffer. To precipitate the eluted plasmid, 3,5ml of isopropanol were added at the elution. This solution was centrifugated during 30 minutes at 10.000 RPM and 4°C. After the precipitation, the supernatant was discarded and the pellet was transferred in Eppendorf® tube.

In this tube, 1ml of Ethanol 70% was added for washing the pellet and then centrifugated at 15.000g for 5 minutes. The pellet was then dried for 5 minutes at 50°C. Finally, the pellet was resuspended in 200µl of water.

II.4.12. Lipofection of bacmids in secondary CEF's:

The day after the creation of secondary CEF's, the lipofection of viral DNA was realized. It's necessary to transfect our DNA on newly secondary CEF's because transfection is more efficient when cells are in growth.

Lipofectamin Reagent® was used for the transfection of secondary CEF. Transfections were occurred on 6 wells plate (P6). Two wells were used for each condition. The transfected conditions were transfected with 1µg DNA/well. To prepare our secondary CEF, media of each well was replaced by 1ml of Gibco® OptiMEM (Opti-Minimum Essential Media) and immediately put at 40,5°C-5% CO₂. Before transfection, lipofection's mixes were created. For each conditions 10X dilutions of bacmids and of lipofectamine were made. For example, 20µl of bacmids were diluted in 180µl of OptiMEM (200µl of OptiMEM for the control condition). In parallel, 20µl of Lipofectamine Reagent were diluted in 180µl of OptiMEM for each condition. Next, the dilutions were rested 5 minutes at room temperature. Then the diluted solution of bacmid were put in the tube containing the lipofectamine dilution. Then this mix was incubated during 20 minutes at Room Temperature. After this incubation, 1600µl of OptiMEM were put in tubes to complete the mixes and to provide fresh media on cells. Then, the OptiMEM of each well of the P6 was thrown away and 1ml of the correspondent mix was put in the appropriate wells. The cells were incubated over 6 hours at 40,5°C -5% CO₂. At the end of incubation, the media was finally replaced by 2,5 ml of secondary media per well.

II.4.13. Titration of viral particles by Indirect Immunofluorescence:

To titer viral particles amplified within secondary CEF's, an indirect immunofluorescence was performed. For each virus (RB1B wt, RB1B+miR-126 wt or RB1B+miR-126 mut) a plate of 24 wells (P24) was seeded with 100 000 cells per wells. These cells were infected at different dilutions. For a P24, 2 wells of non-infected cells were performed. For dilutions, 2 wells were used for the 10⁰ dilution. From this dilution, serial dilutions were done. First a dilution 1/10 following by four 1/5 dilutions (**Fig. 12**). Four wells per dilutions were sowed. The cells were infected for 2 days to allow the formation of foci in each well. After this infection period, cells were fixated with Paraformaldehyde (PAF) 4%. Then, cells were incubated for 15 minutes RT followed by 45 minutes at 4°C or over-night at 4°C. After cells fixation, the PAF was removed and then each well were washed 4 times with 500µl Tampon I (Tris HCl 20 mM ph=8, NaCl 250 mM). After that, cells were permeabilized by an incubation for 30 minutes at 4°C with 500µl of Tampon II (Tampon I + 0,5% de Triton-X100). Following this incubation, cells were washed 4 times with 500µl of Tampon I. Cells were then saturated by an incubation for 1 hour with 500µl of Tampon III at RT (Tampon II + 1% BSA, Bovine Serum Albumine). Four washes with 500µl of Tampon I were realized after the saturation. After these steps, the indirect immunofluorescence can be performed on each well. Cells were first incubated for 1 hour RT with 200µl of VP5 (capsid protein) antibodies diluted at 1/200. After this time, 4 washes with Tampon II were done. Then cells were incubated for 1 hour RT with the secondary antibodies GAM-488 diluted at 1/1000. Four washes with 500µl of Tampon II were performed after this incubation. To reveal nucleus, cells were exposed to DAPI (1µl in 50 mL) for 1 minute RT.

Then cells were washed 1 time with 500 μ l of DBPS. Finally, 500 μ l of DPBS were put over cells to conserve them.

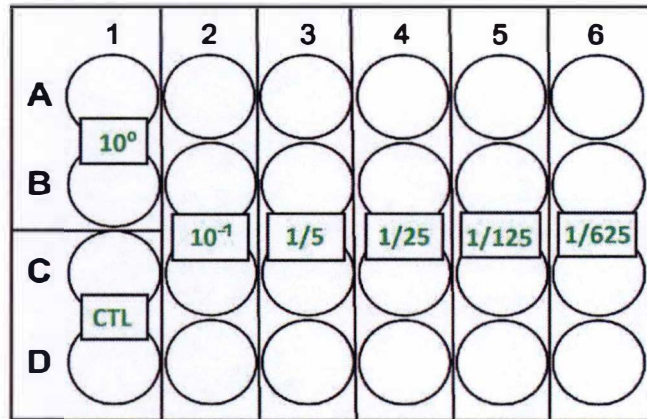

Figure 12: Organization of a P24 used for the viral titration. For the realization of the viral titration a plate of 24 wells (P24) was divided in several parts. Two wells are reserved for a negative control of uninfected cells (CTL), two others are for the infection of non-diluted virus (10^0). Four wells are infected with several dilutions. The dilutions are 10^{-1} , and serial dilution of $1/5$ ($1/5$, $1/25$, $1/125$ and $1/625$)

To calculate the PFU (Plaque-Forming Unit), the following equation was used:

$$\left(\frac{\text{average of foci per condition} \times \text{dilution of the condition}}{\text{Volume put in each well}} \right) \times 1000 = \text{PFU/ml}$$

With this equation, it was easy to calculate the correct volume that carried 1000 PFU in order infect to chicken sensitive to the Marek's disease. Finally, this volume was injected in chicken.

II.4.14. RNA extraction by TRI reagent:

To analyse the overexpression of the miRNA-126 by the recombinant virus developed during this master thesis, RNAs extractions were performed on CEF's infected by the virus. These RNA extractions were made in parallel of each cell passages. Cells were resuspended in 100 μ l of PBS then 1ml of TRI reagent® was added to the resuspensions. These solutions were incubated 5 minutes RT to allow the lysis of cells. These solutions were then centrifugated at 12 000g for 10 minutes at 4°C to pellet cells membranes. The supernatant containing RNA's and DNA was harvested in a new Eppendorf tube. 200 μ l of chloroform was added to this supernatant and the solution was well mixed and then incubated for 15 minutes at room temperature. Then the solution was centrifugated at 12 000g for 15 minutes at 4°C. After this centrifugation, three phases were obtained and the aqueous phase (the upper phase) containing RNA's was transferred in a new tube. 500 μ l of isopropanol was added to the aqueous phase and the solution was vortexed and then incubated 1 hour at -80°C. The isopropanol was used to precipitated RNA's; After this incubation time, the solution was centrifugated at 12 000g for 15 minutes at 4°C. The pellet was thrown away and then 1ml of Ethanol 70% was added for washing the pellet. The resuspension was centrifugated at 7 500g for 5 minutes at room temperature. Finally, the ethanol 70% was removed, the pellet was dried and resuspended in 30 μ l of water.

II.4.15. DNase treatment:

To avoid the presence of DNA in the samples a DNase treatment was made. 5µl of DNase I buffer 10X, 2µl of RNase inhibitor (80U), 6µl of DNase I NEB® (12 U) and 3µl of water was added to the 30µl of RNA to reach the volume of 46µl. The solutions were incubated for 1 hour at 37°C and 4µl DNase I (8U) was added after the first 30 minutes. After the digestion, 150µl of water was added to reach the volume of 200µl and a phenol/chloroform purification was performed.

II.4.16. RNA's purification by Phenol/Chloroform:

Following the DNase treatment of the RNA's samples, a phenol/chloroform purification was realized. Because phenol/chloroform are volatile and toxic compounds, all the manipulations for this purification were realized under a chemical hood. For the first step, the same volume of phenol/chloroform (5:1 ratio) was added at the RNA solution (200µl phenol/chloroform/isoamyl alcohol + 200µl of RNA sample). The phenol and chloroform act by the removal of proteins and lipids out the aqueous phase. The mix was then centrifugated at 12 000 g for 5 minutes at 4°C. Following this step, the upper phase namely the aqueous phase, was collected since it contained the RNA's. Next, an iso-volume of chloroform+ isoamyl alcohol (3-méthylbutan-1-ol) (49:1) was added to the aqueous phase. This step acts also by removal of proteins out aqueous phase. Isoamyl alcohol decreases superficial tension and facilitates separation of the phases. This new mix was centrifugated with the same conditions of the first centrifugation. The new aqueous phase was recovered for completing the purification. Then three volumes of cold ethanol 100% and 1/10 volume of sodium acetate were added to the aqueous phase. This step allows RNA precipitation. This solution was incubated 20 minutes at -80°C. Once defreezed, the solution was centrifugated at 12 000 g for 15 minutes at 4°C. The supernatant was then discarded and 1 ml of ethanol 70% was added on the pellet. This last solution was centrifugated at 7500g for 5 minutes at room temperature. The obtained pellet was then resuspended in 30µl of water.

II.4.17. Reverse transcription specific to miR-126-3p:

To quantify if the recombinant virus (RB1B + 126 WT) well overexpresses the miR-126-3p, a specific reverse transcription was realized on the RNA's samples of each cell passage. To specifically target the miR-126-3p, a gene specific primer (GSP) directed to this miRNA was used to do the reverse transcription. The GSP-miR-126 contains 8 nucleotides directed to the strand 3p of the miR-126. These nucleotides are coupled to a 10 nucleotides universal tail to increase the length of the miRNA. For RNA's concentrations lowest than 1µg, 10µl of RNA's were added to 2µl of GSP-miR-126 and 1µl of dNTP (10mM). This intermediate mix was incubated 5 minutes at 65°C to avoid secondary structure of RNAs during the reverse transcription and then the solution was placed 1 minute on ice. After this incubation time, 4µl of first strand buffer 5X (Invitrogen™), 1µl of dithiothréitol (DTT) 0,1M, 1 µl RNase out (40 U) and 1µl of the super script III (SSIII-200U) reverse transcriptase to reach the final volume of 20µl. The reaction occurred for 1 hour at 55°C and the SSIII was degraded at 70°C for 15 minutes.

II.4.18. Reverse Transcriptase- quantitative PCR (RT-qPCR) directed to miR-126-3p cDNA:

After the procurement of cDNA's from each cell passages, the reaction mix for the RT-qPCR was realized. For one well, 5 μ l of fast Start Universal SYBR Green Master® (Roche™), 0,8 μ l of LNA-miR-126-3p (Locked Nucleic Acid; 10 μ M) forward primer, 0,8 μ l of universal reverse primer (UP; 10 μ M) and 1,4 μ l of water were added to reach the volume of 8 μ l. The UP primer recognizes the universal tail and the LNA-miR-126-3p recognizes the strand-3p of the miR-126. LNA™ primers (Exiqon) are short sequences (15bp) composed by 2 modified RNA nucleotides. The modification is a bond between the 2' oxygen and the 4' carbon atoms (**Fig. 13**). The modified nucleotides increase the hybridization stability of the LNA primer to small RNA's such as miRNA's. When the RT-qPCR mix were added in each well of the plate, 2 μ l of cDNA's were put to the reaction mix. The RT-qPCR program is composed by a first step of 3 minutes at 95°C. Then a cycle composed by 3 steps (30 seconds at 95°C, 30 seconds at 55°C and 30 seconds at 72°C) was repeated 42 times. Finally, to assess the melting curves control, one step of 30 seconds and two steps of 15 seconds and respectively of 95°C, 55°C and 95°C ended the reaction.

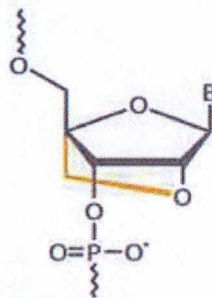

Figure 13: Representation of a Locked Nucleotide (LN) used in Locked Nucleotid Primers®. The locked nucleotide is modified by a bond between de 2' oxygen and the 4' carbon atoms of the ribonucleotide.

III. Results:

III.1. Development of a GaHV-2 recombinant virus to restore miR-126 expression:

This master thesis aims at contributing to a research project that addresses miR-126 function in the context of a viral induced lymphoma. Following this master thesis, miR-126 restoration will be tested through the viral infection of susceptible animals with a recombinant GaHV-2 expressing miR-126. Thus, the determinant step in this process is to develop recombinant GaHV-2 virus carrying a functional miR-126 expression system.

To develop this recombinant virus, several steps of mutagenesis were performed on the viral genome maintained in bacteria. First, a miRNA expression system containing transient Kanamycin resistant gene was developed. Then a transfer amplicon was generated to incorporate the miRNA expression system into the viral RB1B genome cloned as BAC by the "en passant" insertion mutagenesis.

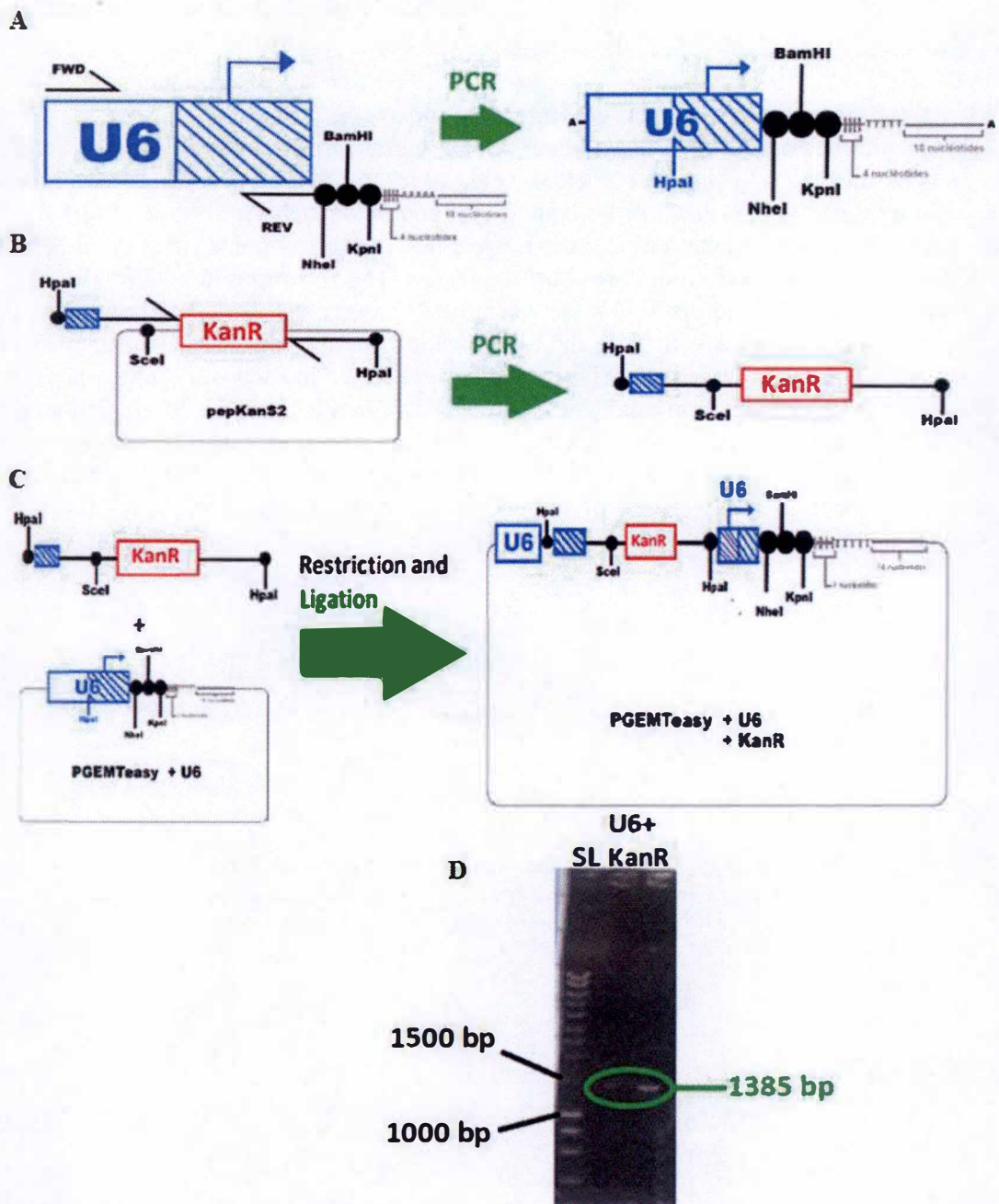

Figure 14: Representation of the different steps to clone U6 promoter with KanR cassette in pGEMTeasy®

A) Amplification of The U6 promoter by PCR. The U6 promoter is represented in blue. The hatched part in the promoter is the region that will be duplicated. The grey part on the reverse primer is composed of 4 nucleotides (vertical bars), used as spacer, a stretch of adenosine and 10 random nucleotides. **B)** The KanR cassette (aphA-I gene) (red square) is amplified from the pepKanS2 plasmid. The blue hatched box represents a homologous region of U6 promoter. **C)** To create the pGEMTeasy+U6+KanR vector, both pGEMTeasy+ U6 and the KanR PCR product were first digested by the HpaI enzyme. Then they were ligated by the T4 DNA ligase. **D)** Gel migration of PCR products amplified by PU primer and reverse primer directed to KanR. PCR products has a size of 1385 bp length. The SmartLadder (200bp-10kbp) SL was used as ladder. Black arrows represent primer used for PCR amplifications. The black balls are restriction sites (NheI, BamHI, KpnI, HpaI and Scel).

III.1.1. Development of miRNA expression system containing transient Kanamycin resistant gene.

The first step for development of this miRNA expression system is the amplification of the chicken U6 promoter (RNA-Pol III). This promoter was chosen because it shows a high and constitutive activity and it contains a unique restriction site to HpaI. This site was used to allow incorporation of a transient resistance gene to Kanamycin (*aphA-I* gene). By high-fidelity PCR, the promoter was amplified. The reverse primer carried a specific sequence composed of three restriction sites (NheI, BamHI and KpnI), four spacers nucleotides, a small stretch of polyT (5 T) and ten spacers nucleotides. Poly-T stretch is the signal for transcription termination of RNA Polymerase III. The three restriction sites, NheI, BamHI and KpnI will be useful for subsequent cloning steps (Fig. 14.A.). After PCR amplification, an adenosine was added at each extremities of the PCR product (Fig. 14.A.). This protruding adenosine was used for the TA cloning of the U6 PCR product into pGEMTeasy vector. In parallel, PCR amplification of the resistance gene cassette (KanR) was performed. Indeed, the Kanamycin resistance gene (*aphA-I*) was amplified from the pepKanS2 plasmid by high-fidelity PCR (Fig. 14.B.). Both primers carried a restriction site for HpaI enzyme that was used for ligating the Kanamycin resistance gene into the U6 promoter.

In addition, the forward primer used to anneal the sequence before KanR gene contains a restriction site for ScaI enzyme. This site will be used for removal of the resistance cassette. The forward primer contains also at its extremity a homology spot with the U6 sequence after HpaI site (Fig. 14.B.) (Table 2).

Both the PCR product of KanR and the pGEMTeasy+U6 vector, was restricted with HpaI. Then the two products were ligated to form the pGEMTeasy+U6+KanR vector (Fig. 14.C.). This ligation product was then transformed into DH10B bacteria to amplify it.

To test if bacteria contains the pGEMT+U6+KanR vector, a PCR screening was realised. The primers were directed to pGEMT plasmid (PU primer) and to KanR cassette (Table 2). The expected size product is 1385 bp. As shown on figure 14.D, the product with the appropriate length was obtained. This result confirmed that the construct was in proper orientation. Thereafter, the next step needed for the creation of a miRNA expression system was realized.

To develop this system, the pre-miR-126 (miR-126 wt) and mutated pre-miR-126 (miR-126 mut) were amplified. These sequences were both extracted from DNA of the chicken MSB1 lineage. The mutated version of pre-miR-126 was obtained by site directed mutagenesis based on overlapping fragments bearing the mutated seed sequence of miR-126 (Fig. 15.A.). Forward and reverse primers carried respectively NheI and KpnI restriction sites (Fig. 15.A.). Then both pGEMT+U6+KanR and miR-126 wt and miR-126 mut products were restricted with both NheI and KpnI enzymes. Next to this, a ligation was performed to integrate the pre-miR sequences into the pGEMT+U6+KanR vector. The pGEMT+U6+KanR+wt-miR-126 or mut-miR-126 plasmids were then isolated, amplified and sequenced. (Fig. 15.B.). The vectors contained the miRNA expression system and the sequences needed for the “en passant” mutagenesis insertional mutagenesis.

Table 2: Primers used for the creation of the recombinant viruses (RB1B+126wt and RB1B+126mut)

	NAME	SEQUENCE 5' → 3'	TM (°C) AND LEGEND
1	ChU6-3-prom-fwd	CAGACAGACGTCAGGCTTTC	Tm = 55,28
2	ChU6-3-prom-nheI-126-rev	<u>ATGGATGTGCGCTAGCG</u> ACTAAGAGCATCGA GACTG	Tm short = 49,3 Tm long = 80,19 <u>Seq. of homology with gga-premiR-126</u> Seq. <u>NheI</u> site
3	PremiR126-nheI-U6-3-fwd	<u>GCTCTTACTC</u> GCACATCCATCCGGA GCCACAAG	Tm short = 70,3 Tm long = 86,06 Seq. <u>NheI</u> site
4	PremiR126-BamHI-kpnI-poIII-rev	CTGATGCTACA <u>AAAA</u> AGATC <u>GGATCC</u> GACGCATGTAGATGGCTCTCCAG	Tm short = 66,9 Tm long = 91,53 Seq. of <u>BamHI</u> <u>Terminal seq. poIII</u>

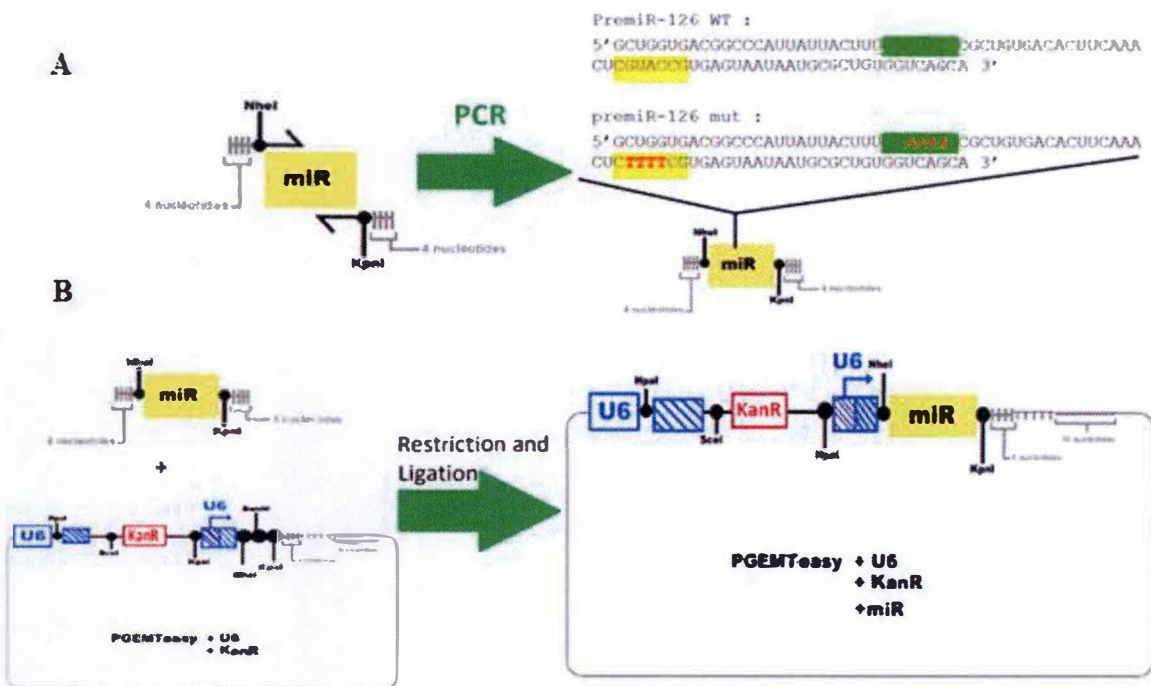

Figure 15: Representation of the cloning steps of the sequence for pre-miR-126 wt or 126 mut into pGEMT+U6+KanR. **A)** The sequence of wt-pre-miR-126 and mut-miR-126 (yellow box) were amplified by PCR. The sequence of wt/mut-pre-miR-126 are shown with the seed sequence (highlighted in yellow) and its complementary region (highlighted in green). **B)** To create the pGEMT+U6+KanR+miR vector, both pGEMT+U6+KanR and the pre-miR PCR product were first digested by both NheI and KpnI enzymes. Then they were ligated by using T4 DNA ligase. Black arrows represent primers. The grey vertical bars represent 4 random nucleotides use for the docking of the restriction enzyme. Black balls represent restriction enzyme site (NheI, KpnI, SclI and HpaI). U6 promoter is represented in blue and the kanamycin resistant gene is represented in red.

III.1.2. Production of transfer amplicon (T.A.) to incorporate the miRNA expression system inside the viral pRB1B-5 bacmid:

To integrate the miRNA expression system in the viral genome RB1B, amplification of two 50bp stretches of homology with the RB1B BAC is necessary. Primers used for this amplification carried homology regions with the viral bacmid DNA. Indeed, forward primer bore a region of 50bp homology with US2 gene of the GaHV-2 genome. The reverse primer bore a region which is homologous with the mini-F vector inside the BAC cassette integrated into the GaHV-2 bacmid (Table 2). This PCR was carried out to produce the transfer amplicon gathering the U6 promotor, the Kanamycin resistance gene and the wt-pre-miR-126 or mut-pre-miR-126 sequence surrounded with the two 50bp regions needed for the homologous recombination (Fig. 16.A.). This transfer amplicon was later used to be transformed into GS-1783 strain of *E. coli* where it was integrated into pRB1B-5 bacmid. As visible on figure 16.B, the transfer amplicons with a length of 1675 bp were obtained after gel migration of PCR products. The following step is the transformation of the two T.A. on GS-1783 strain of *E. coli*.

Table 2. Primers used for the creation of the recombinant viruses (RB1B+126wt and RB1B+126mut)

5	PEPKanS2-U6-3-HpaI-fwd	GACTGTTAACAGATGGTCTATTAGCGG GCCTTTGCTGGGAGGATGGAGTAGTCA TAGGGATAACAGGGTAATCGATTI	Tm short = 57 Tm long = 69 Seq. HpaI site 3' homology seq. pEP-KanS2 seq.
6	PEPKanS2-HpaI-rev	GACTGTTAACGCCAGTGTTACAACCAATTA ACC	Tm = 56.8 Seq. HpaI site PEP-KanS2 seq.
7	Amplicontransfert-U6-3-fwd	TCAGGCTTTC CAGACAGACG	Tm short = 55 Tm long = 69 3' homology seq.
8	Amplicontransfert-miR-rev	TTAATTAAAGGCGCAGCTTCCTAGATAAC TCGTATAGCATAACAATTATACCTGATGCTAC AAAAAGATC	Tm short = 55 Tm long = 66.8 BAC cassette insertion seq. Terminal seq. polyIII Seq. NotI site
9	MiR126-mut-fwd	AAAAGCGCTGTGACACTTCAAACT CTTTTCGTGAGTAAT (GTACGCGCTGTGACACTTCAAAC TCGTACCGTGAGTAAT)	Tm = 58,4 Mutation on seed seq. and homology seq. of the seed Wild-type seq.
10	MiR126-mut-rev	AAAAGAGTTTGAAGTGTCACAGCG CTTTTCAAAGTAAT (GTACGAGTTTGAAGTGTCACAGC GCGTACCAAAGTAAT)	Tm = 56,3 Mutation on seed seq. and homology seq. of the seed Wild-type seq.

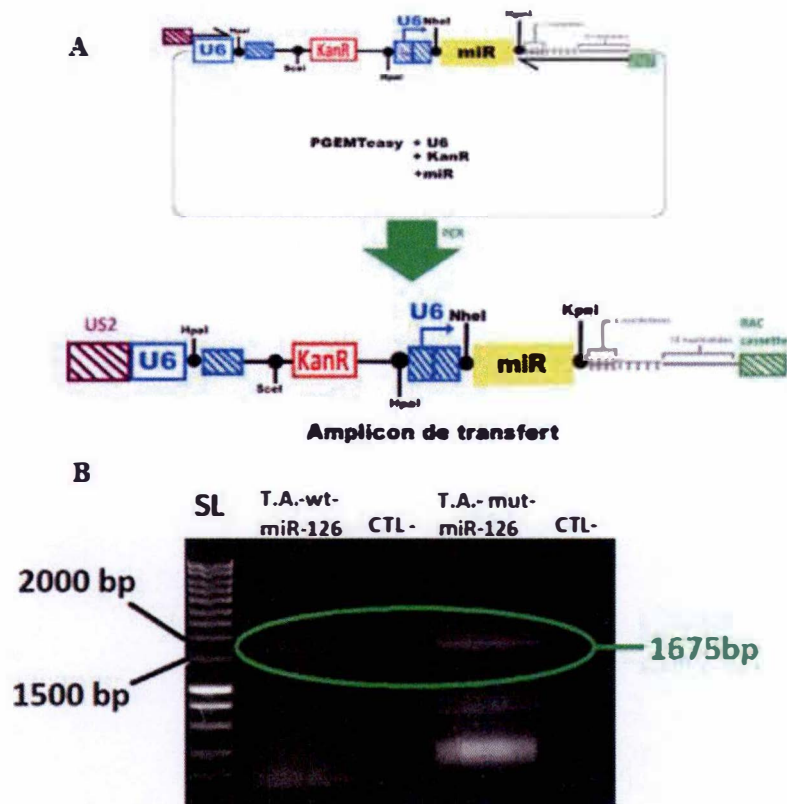

Figure 16: Schematic representation and results of the transfer amplicon produced by PCR. **A)** step representing the amplification of the amplicon of transfer (A.T. miR-126/126*). The purple hatched box represents the US2 homology sequence. The green hatched box represents the bac homology sequence. The promoter U6 is represented in blue. The kanamycin resistant gene is represented in red and the pre-mir sequence is represented in yellow. **B)** Gel electrophoresis of PCR products to obtain transfer amplicon. Both transfer amplicon showed the length of 1675 bp. The Smart Ladder SL (200bp-1KBP) was used and negative controls for both condition were realized.

III.1.3. Generation of wt-miR-126 or mut-miR-126 of recombinant RB1B bacmids by the “en passant” insertion mutagenesis:

The GaHV-2 strain pRB1B-5 bacmid is replicated as a low-copy plasmid inside GS-1783 *E. coli* strain. These bacteria are genetically modified to bear in their genome two inducible promoters. First, a thermo-inducible promoter that expresses the RED system of homologous recombination at 42°C. This RED system catalyses the “en passant” mutagenesis that will allow the integration of transfer amplicons (miR-126 or miR126*). The RED system is composed of 3 genes from the λ phage: *gam*, *exo* and *bet*. First *gam* gene expresses a protein that protects DNA double strand from the bacterial RecBCD helicase complex. Secondly, *exo* gene encodes for a 5'-3' exonuclease that allow formation of protruding single strand DNA. Finally, *bet* gene encodes for a single-strand binding protein that allow ligation of two single strand DNA and protects these single strands from degradation. The second promoter is inducible by a solution of L-Arabinose (2%) and triggers the expression of the *Sce*-I enzyme necessary for removal of the Kanamycin resistance cassette.

When the transfer amplicons (wt-miR-126 or mut-miR-126) were transformed in GS-1783, the RED system of homologous recombination was induced to trigger their integration into pRB1B-

5 DNA. The insertion sites correspond to the viral US2 gene (upstream) and to the mini-F region of the BAC cassette containing a resistance gene to Chloramphenicol (downstream) (Fig. 17.A). Following insertion of transfer amplicons in viral genome, transformed bacteria were selected on Chloramphenicol and Kanamycin.

Successful recombinant events were monitored and demonstrated by the PCR screening performed on colonies. Indeed, several colonies were shown to possess both viral gene encoding the capsid protein VP5 and the U6-Kanamycine region (Fig. 17.B). Next to this screening only wt-miR-126 was integrated into RB1B genome. For now, next steps were realised only for pRB1B-5 bearing wt-miR-126 transfer amplicon.

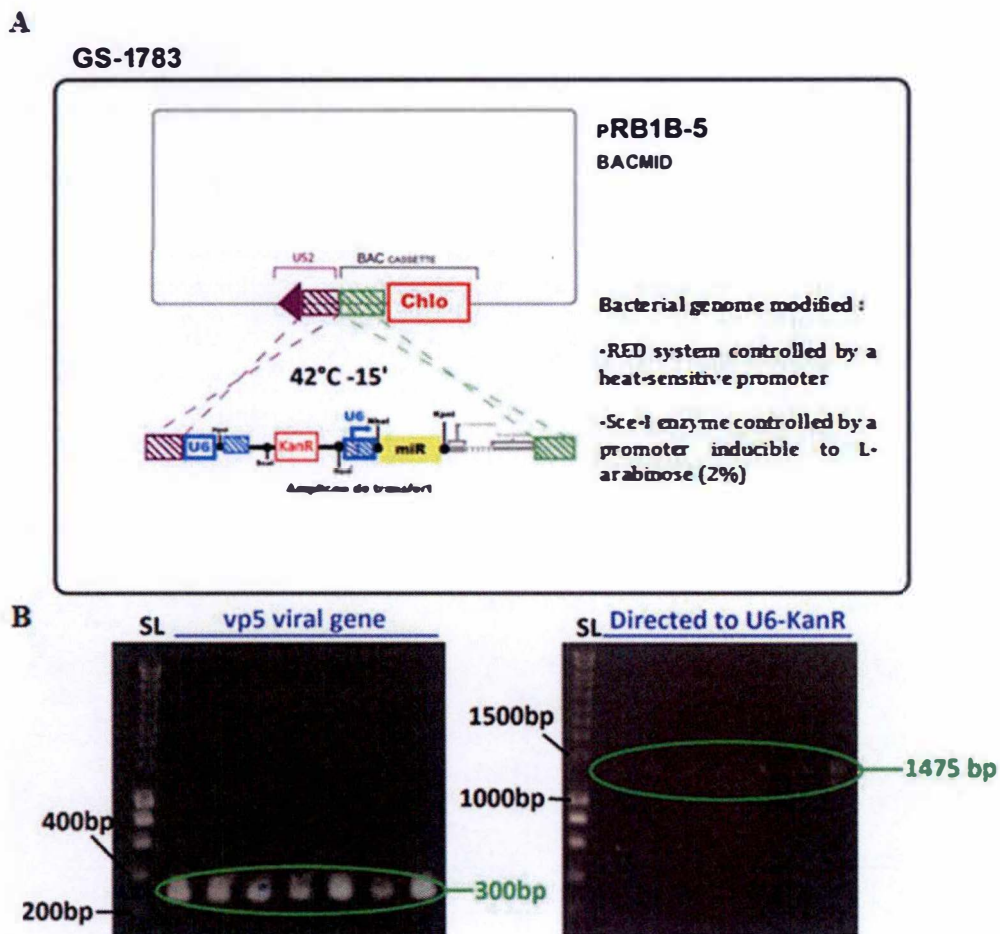
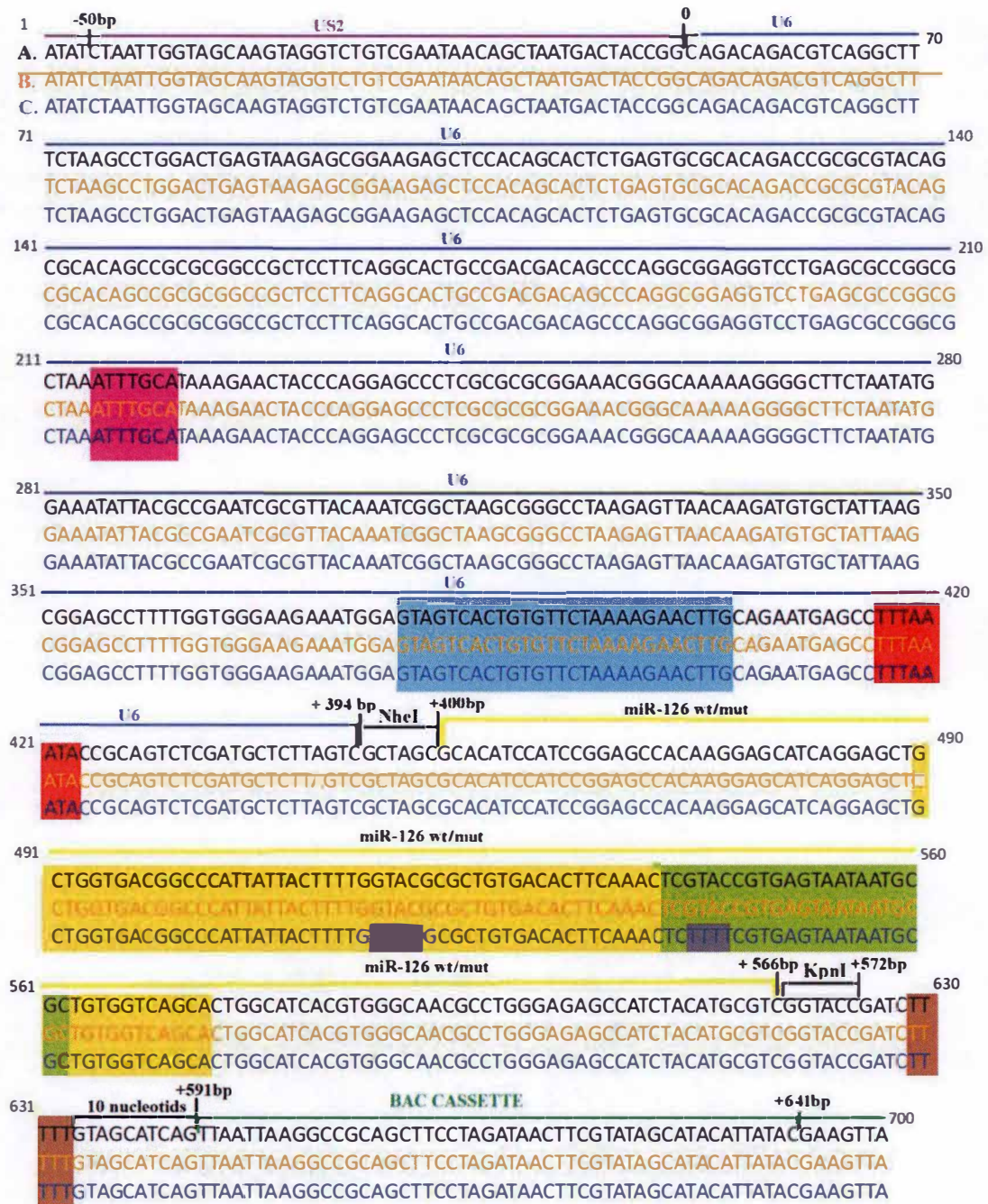

Figure 17: Schematic representation and results of the Insertion of wt-mir-126 transfer amplicon in GS1783 bacteria. A) the big square represents the GS1783 bacteria with the RB1B BAC inside. The purple hatch box is the US2 region. The green hatch box is the bac cassette region. Red boxes represent resistant genes to kanamycin and chloramphenicol (KanR & Chlo). Insertion of transfer amplicon into the RB1B BAC between US2 gene and BAC cassette by the “en passant” mutagenesis. This insertion was induced by activation of RED system by incubation 15 minutes at 42°C. BAC cassette contains a restriction site to Chloramphenicol. B) Screen PCR on GS-1783 to check integration of the U6+KanR+miR-126wt/mut transfer amplicons. For both gel Smart Ladder SL was used. The screen directed to vp5 shows PCR products of 300bp. The screen directed to U6-KanR shows PCR products of 1475bp confirming the presence of transfer amplicon.



Caption:

	TATA box	miR-126-3p	Poly-T signal
PSE	Pre-miR-126	mutations of miR-126mut	

A. Reference sequence
 B. RB1B +126 wt
 C. RB1B +126 mut

Figure 19: Sequence alignment of RB1B+126wt and RB1B+126mut obtained after sequencing with the reference sequence designed during the project. The reference sequence (A.) is aligned to the sequence of the PCR products of miR-126wt (B.) and miR-126mut (C.) expression system at its insertion site inside RB1B genome. The miR-126wt/mut expression system is limited between the 0bp and the +591bp markers. The expression system is composed by the U6 promoter (0bp to +394bp), the NheI restriction site (+395bp to +400bp), the miR-126wt/mut precursor sequences (+401bp to +566bp), the KpnI restriction site (+567bp to +572bp), the Poly-T signal (+577bp to +581bp) and the 10 nucleotides sequence (+582bp to +591bp). The RB1B US2 (-50bp to 0bp) and BAC cassette (+592bp to +641bp) are respectively show in purple and in green.

The final step of the process was to get rid of the Kanamycin resistance gene in order to restore the U6+miR-126 wt/mut expression system within the recombinant BAC. To do this, Sce-I enzyme was induced by L-Arabinose. This induction could specifically digest bacmids at the Sce-I restriction site. In parallel, the RED system was restored for a second time to trigger the homologous recombination between the U6 regions (scratched blue boxes) (Fig. 18.A.). At the end of this process, the Kanamycin resistance was removed of the U6+miR-126wt/mut expression system inside the RB1B BAC (Fig. 18.B.). The bacterial clones containing the recombinant BACs were selected on Chloramphenicol but not on both Chloramphenicol and Kanamycin. Then the recombinant RB1B+126wt or RB1B+126mut genomes were purified from the selected clones. Finally, to verify if there were no mutation inside the miRNA expression system, a PCR with primers directed to the US2 region and the BAC cassette was carried out (Fig. 18.B.). This resulting PCR products were sent to the sequencing (Eurofins genomics™). As shown on the Figure 19, the miR-126wt and the miR-126mut sequences corresponding to the reference sequence were obtained, indicating that the whole cloning strategy was successful.

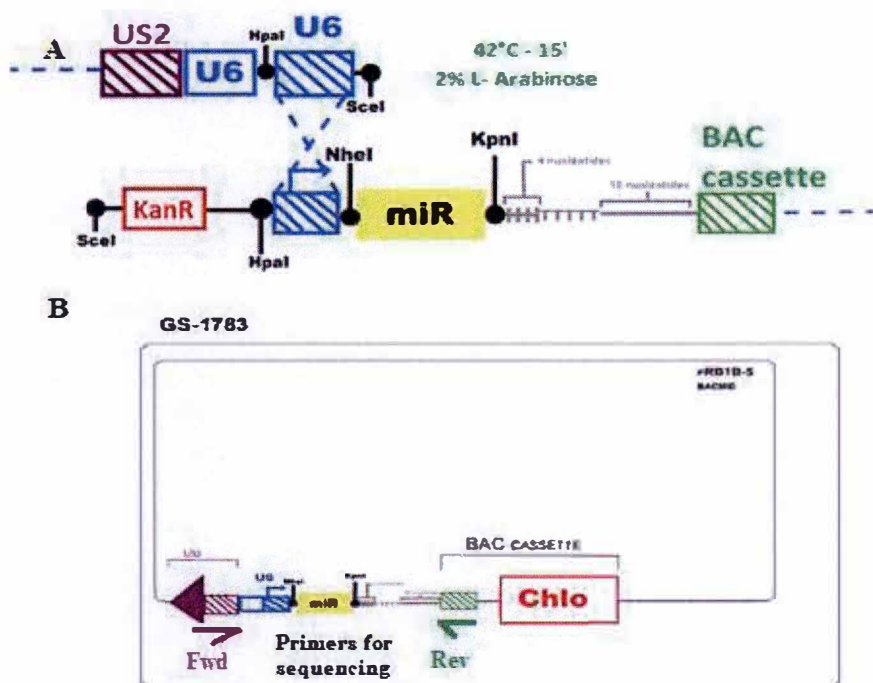

Figure 18: Schematic representation of the KanR removal out of miRNA-expression system. A) Step representing the removal of KanR cassette by “en passant” mutagenesis between U6 homology regions (hatched blue boxes). This removal is catalyzed by the RED system following 15 minutes of incubation at 42°C. US2 gene is displayed in purple. The BAC cassette is displayed in green. Resistance gene is displayed in red. B) Representation of GS-1783 containing recombinant pRB1B-5 with the miRNA expression system. To sequence the miR expression system, a PCR was assessed with a forward primer directed to the US2 region (Fwd) and a reverse one directed to the BAC cassette (Rev).

III.2. Amplification and titration of the recombinant viruses

To produce viral particles of these two recombinant viruses of GaHV-2 (RB1B+126wt/+126mut), the recombinant BACs were transfected into chicken embryo fibroblasts (CEF). Within these cells the recombinant GaHV-2 genomes were able to produce viral particle. As mentioned in the introduction, GaHV-2 is an intracellular and free viral particle are not produced. So, to produce viral stocks, the primary infected CEFs were submitted to 10 successive passages on freshly prepared cells. In addition, aliquots were frozen in order to prepare inoculum for infecting chicken. Beside these two recombinant viruses, the RB1B wt strain was also amplified and stored.

In prevision of the future *in vivo* experiment, the RB1B wt strain of GaHV-2 and the two recombinant viruses were titrated. Because of the cell to cell spreading of GaHV-2, an immunofluorescence approach was used for assessing viral titers. Thanks to an antibody raised against the capsid protein VP5 the viral foci were visible by fluorescence (Fig. 20) and thus the infected cell suspensions were titrated. Indeed, small foci might be not discriminated with the optical microscope. Thus, the immunofluorescence is a preferred method to identify each viral replication foci. The titer of each viruses per milliliter was calculated by counting all the isolated foci at one dilution. To obtain well isolated foci, serial dilutions of the wild-type and the recombinant viruses were done. Finally, the volume for a subsequent *in vivo* infection was measured to reach 1000 PFU per inoculum corresponding to the classical infections dose used in MDV research field (Fig. 21).

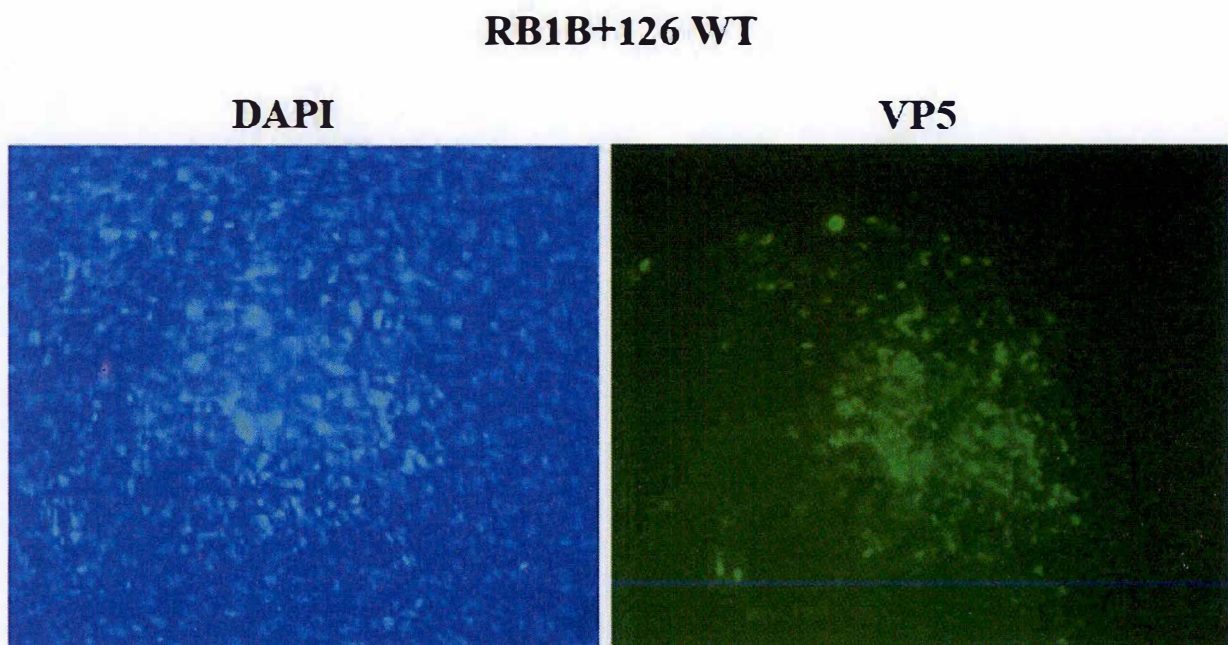
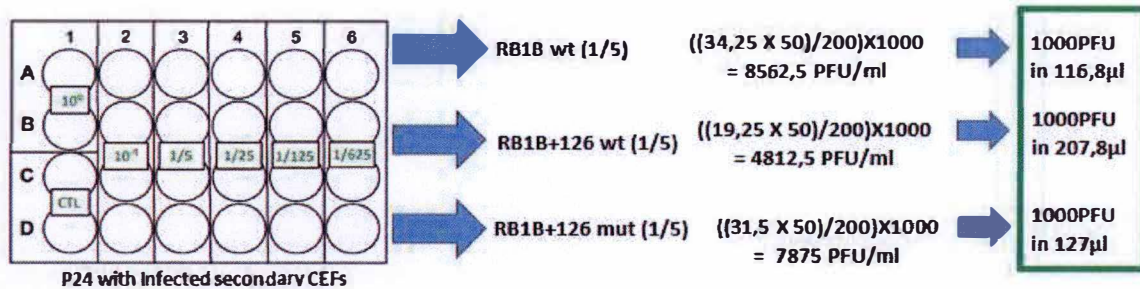

Figure 20: Fluorescent micrography of a viral focus of the recombinant RB1B+126 wt virus. On the left picture, the nucleus of CEFs are visible by the DAPI nucleus marker (DAPI). On the right picture, the viral focus is visible thanks to the fluorescence raised against the VP5 capsid protein (VP5).



$$\left(\frac{\text{average of foci per condition} \times \text{dilution of the condition}}{\text{Volume put in each well}} \right) \times 1000 = \text{PFU/ml}$$

Figure 21: Results of the viral titrating using the immunofluorescence directed to the VP5 capsid protein. The plaque forming unit (PFU) for each virus was measured from the foci present in the 50X dilutions wells with the present equation. The volumes of infected cells containing 1000PFU of each virus are in the green box. These volumes correspond to the inoculum that will be used for *in vivo* trials.

III.3. Assessment of miR-126 wt or miR-126 mut overexpression:

In the next step of the research the level of miR-126 overexpression (wt or mut) was checked during the amplification of reconstituted recombinant viruses. To do this, a preliminary test of the miR-126 wt and miR-126 mut overexpression was performed in parallel of the amplification of the three types of viruses (RB1B wt, RB1B+126 wt and RB1B+126 mut). A RT-qPCR was setup in order to measure miR-126 (wt or mut) expression.

During the amplification of the viruses, total RNAs were collected from CEFs at passage 1, 5, 6, 7, 8, 9 and 10. The second, third and fourth passages were not analyzed because all the infected cells were used to ensure the transmission to the freshly prepared CEF monolayer. A RT-qPCR, directed to miR-126 wt was realized on RNAs from the cells infected by RB1B wt and RB1B+miR-126wt. For the condition infected with the RB1B+miR-126 mut, the RT-qPCR was directed to the mutated version of the miRNA.

This preliminary experiment showed no difference between Cq of the RB1B wt condition and the miR-126 wt/-126 mut conditions at the first passage of the viral infection (P1) (Fig. 22). MiR-126 wt and miR-126 mut were not detected on this first step. From the fifth (P5) to the tenth (P10) passage, a decrease between 7 to 10 Cq was observed for the recombinant RB1B+126wt in comparison with the condition infected with RB1B wt (P5-10) (Fig.22). But from P5 to P10 for CEFs infected by RB1B+126mut, the Cq value (miR-126 mut) oscillating between 25 and 32 Cq values. Compared to the threshold at 42 cycles, the CEFs infected by the RB1B+miR-126mut shown a Cq decreased between 10 and 17 Ct.

During a RT-qPCR, the cDNA of interest is amplified at each cycle following the relation: 2^x where x is the number of cycle. So, based on this relation a decreased of 7 to 10 Cq (observed for miR-126wt) is equal to an overexpression of 128 (2^7) to 1024 (2^{10}) of this miR compared to cells infected with the wt virus (RB1B wt). Furthermore, for miR-126mut the

decrease of 10 to 17 Cq compared to the threshold limit (42 cycles) shows a hypothetical overexpression of 1024 (2^{10}) to 131 072 (2^{17}) times more.

The overexpression needs to be validated and consolidated because these data were preliminary results and were not normalized. In this way, additional and better controlled experiment to check out the overexpression of the miRNAs of interest is now in progress.

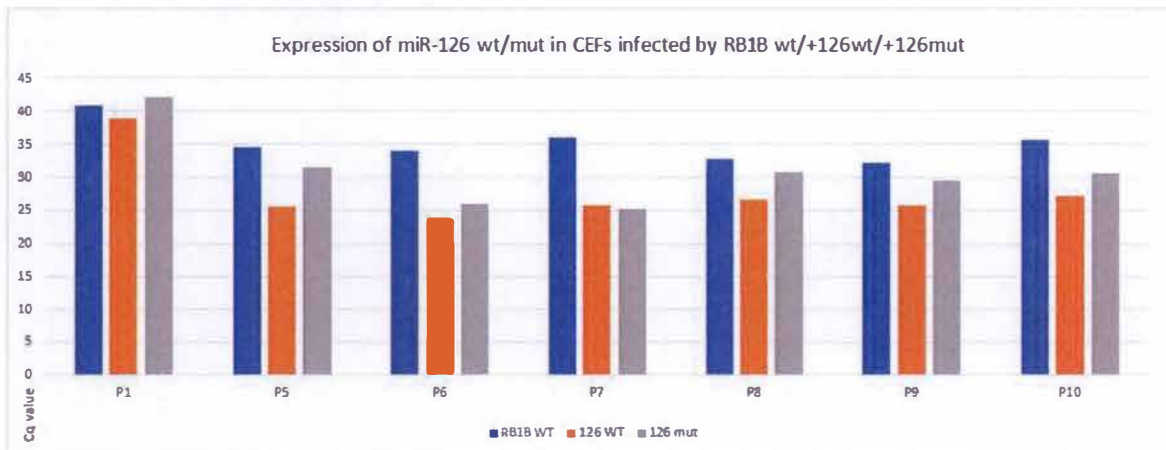

Figure 22: Quantification of miR-126 wt or miR-126 mut by RT-qPCR from recombinant viruses. The Ct values for each cell passages (P1; P5-P10) are shown from infected CEFs by RB1B wt (blue histograms), RB1B+126 wt (orange histograms) and RB1B+126 mut (grey histograms).

IV. Discussions:

During this master thesis, the principal aim was the development of a recombinant virus that is able to express the miR-126wt that is suspected to be a tumor suppressor in the context of lymphomagenesis induced by GaHV-2 infection causing the Marek's disease. In the first part of the project, the viral genome was modified to contain an expression system of the miR-126 wt. This expression system was successfully integrated inside the genome of the RB1B strain of GaHV-2. This insertion was performed thanks to the "en passant" mutagenesis that presents the major advantage to be scarless for the viral genome. Indeed, some mutagenesis methods, such as the Flippase/ Flippase Recognition Target (Flp/FRT) recombination, leave a scar (FRT site) inside the genome (Labaille, 2013). In the context of the Marek's disease, the majority of studies used recombinant mutagenesis to developed recombinant viruses showing a particular deletion. The creation of these "deletant" viruses enable functional studies of several GaHV-2 genes such as Meq or vTR (Trapp *et al.*, 2006) or regions such as the 5'LAT or Mid-cluster regions (Labaille, 2013; Teng *et al.*, 2017). Insertional recombinant viruses of GaHV-2 are scarce. It is likely that an insertion of a foreign DNA sequence within the genome may modified all the physiology of the viral infection. In the case of this project the insertion was done inside the previously disrupted *US2* gene. As said before the protein encoded by this gene is unessential for the GaHV-2 infection and tumorigenesis (Petherbridge *et al.*, 2003).

One of the difficulty linked to the GaHV-2 viral cycle is the assessment of the viral titration. Indeed, because the fact that GaHV-2 is transmitted by cell to cell spreading with no production of free viral particles. A specific titration method is used in the GaHV-2 studies named immunofluorescence (IF). This titration was realized to easily reveal infection foci shaped due to viral infection. A second difficulty linked to intracellular persistence is the low level in the

GaHV-2 titer. Indeed, viruses producing free viral particles reach higher viral titer than GaHV-2. To highlight this difference, serial dilutions for human Herpes Simplex Virus-1 (HSV-1) can reach 10^{-10} in comparison with the maximum dilution (1/6250) used for GaHV-2 titration (Blaho *et al*, 2005). This fact demonstrates the difficulty to produce a lot of GaHV-2 particles.

For now, the preliminary result of the overexpression of the miR-126 wt and miR-126 mut showed a significant decrease in the Cq values suggesting a massive overexpression of both versions of the miR-126. But these results need to be confirmed through a more robust quantification experiment. Indeed, data need to be normalized to quantify exact level of overexpression by the U6-miR-126 wt/mut system. These experiments are in progress.

V. Perspectives of the project:

As mentioned above, a new experiment is in progress to assess the kinetic and the normalized overexpression of the micro-RNAs-126 wt/mut. In comparison with the preliminary test, RNAs from the first to the tenth cell passages will be analysed. To normalize these results, six reference genes will be quantified (Glyceraldehyde-3-phosphate dehydrogenase (GAPDH), β -actin, U6, hydroxymethylbilane synthase (HMBS), 18S RNA and the Succinate dehydrogenase (SDHA)). The three steadiest will be selected by the GeNorm software. DNA extractions from infected cells at each cell passage will be used to determine the number of genome copy for the three viruses by quantifying viral VP5. In parallel, a viral titration using immunofluorescence will be done for the fourth, seventh and tenth passages of the viral infection. Moreover, thanks to these titrations and to the Kolmogorov-Smirnov statistically tests on the phenotype size of the infection foci for each virus will be assessed. This test will determine whether a significant difference exists in the size of the foci induced by the RB1Bwt, RB1B+126wt or RB1B+126mut infections.

The presence of NheI and KpnI, restriction sites next to the U6 promoter, provide the possibility to introduce the sequence of any miRNAs. So, another miRNA could be coupled with this promoter and then integrated within GaHV-2 genome. So, this expression system is an easy tool to overexpress *in vitro* and *in vivo* repressed miRNAs (miR-150, miR-223), that are suspected to be tumor suppressive, in the context of the GaHV-2 infection. So, following this master thesis new recombinant viruses expressing other repressed miRNAs following the lymphomagenesis may be developed. To go further on this way and to test the biological effects of an overexpression of repressed cellular miRNAs suspected to be tumor suppressive in the context of GaHV-2 infection, recombinant viruses containing a clustered expression system of these miRNAs (miR126 + miR150 + miR223) will be developed in a future master thesis.

VI. Bibliography

Almeida, M. I., Reis, R. M., & Calin, G. A. (2011). Mutation Research / Fundamental and Molecular Mechanisms of Mutagenesis MicroRNA history: Discovery, recent applications, and next frontiers. *Mutation Research-Fundamental and Molecular Mechanisms of Mutagenesis*, **717**, 1–8.

Atkins, K. E., Read, A. F., Savill, N. J., Renz, K. G., Islam, A. F. M., Walkden-Brown, S. W., & Woolhouse, M. E. J. (2013). Vaccination and reduced cohort duration can drive virulence evolution: Marek's disease virus and industrialized agriculture. *Evolution*, **67**, 851-860.

Baigent, S. & Davison, F. (2004). Marek's disease virus: biology and life cycle. In *Marek's Disease: An evolving Problem*, 62-77. Edited by F. Davison & V. Nair. London: Elsevier Academic Press.

Barrow, A. D., Burgess, S. C., Baigent, S. J., Howes, K. & Nair, V. K. (2003). Infection of macrophages by a lymphotropic herpesvirus: a new tropism for Marek's disease virus. *J Gen Virol.*, **84**, 2635-2645.

Blaho, J. A. (2005). Herpes Simplex Virus: Propagation, Quantification, and Storage. In *Current protocols in microbiology*. Research Gate.

Brune, W., Messerle, M., Koszinowski U. H. (2000). Forward with BACs: new tools for herpesvirus genomics. *Trends in Genetics*, **16**, 254-259.

Burgess, S. C., Young, J. R., Baaten, B. J., Hunt, L., Ross, L. N., Parcels, M. S., Kumar, P. M., Tregaskes, C. A., Lee, L. F. & Davison, T. F. (2004). Marek's disease is a natural model for lymphomas overexpressing Hodgkin's disease antigen (CD30). *Proc Natl Acad Sci USA.*, **101**, 13879-13884.

Calnek, B. W., Adldinger, H. K. and Kahn, D. E. (1970). Feather Follicle Epithelium: A Source of Enveloped and Infectious Cell-Free Herpesvirus from Marek's Disease. *Avian dis.*, **14**, 219-233.

Churchill, A. E. & Biggs, P. M. (1967). Agent of Marek's disease in tissue culture. *Nature*, **215**, 528-530.

Churchill, A. E., Chubb, R. C. & Baxendale, W. (1969). The attenuation, with loss of oncogenicity, of the herpes-type virus of Marek's disease (strain HPRS-16) on passage in cell culture. *J Gen Virol.*, **4**, 557-564.

Coupeau, D. (2011). Etude transcriptionnelle et post-transcriptionnelle de la région IRL/TRL du virus de la maladie de Marek.

Davison, A. J. (2002). Evolution of the herpesviruses. *Veterinary Microbiology*, **86**, 69–88.

Davison, F., & Venugopal, N. (2004). Marek's disease an evolving problem. *Institute for animal health*, 62-76.

- Fire, A., Xu, S., Montgomery, M. K., Kostas, S. A., Driver, S. E., & Mello, C. C. (1998). Potent and specific genetic interference by double-stranded RNA in *Caenorhabditis elegans*. *Nature*, **391**, 806–811.
- Furlong, D., Swift, H., & Roizman, B. (1972). Arrangement of Herpesvirus Deoxyribonucleic Acid the Core, **10**, 1071–1074.
- Guo, C., Sah, J. F., Beard, L., Wilson, J. K.V., Markowitz, S. D., & Guda, K. (2008). The noncoding RNA, miR-126, suppresses the growth of neoplastic cells by targeting phosphatidylinositol 3-kinase signalling and is frequently lost in colon cancers. *Genes, chromosomes & cancer*, **47**, 939-946.
- Jones, D., Lee, L., Liu, J. L., Kung, H. J. & Tillotson, J. K. (1992). Marek disease virus encodes a basic-leucine zipper gene resembling the fos/jun oncogenes that is highly expressed in lymphoblastoid tumors. *Proc Natl Acad Sci U S A.*, **89**, 4042-4046.
- Kishi, M., Bradley, G., Jessip, J., Tanaka, A. & Nonoyama, M. (1991). Inverted repeat regions of Marek's disease virus DNA possess a structure similar to that of the sequence of herpes simplex virus DNA and contain host cell telomere sequences. *J Virol.*, **65**, 2791-2797.
- Kuhnert, F., Mancuso, M. R., Hampton, J., Stankunas, K., Asano, T., Chen, C.-Z., Kuo, C. J. (2008). Attribution of vascular phenotypes of the murine *Egfl7* locus to the microRNA *miR-126*. *Development*, **135**, 3989-3993.
- Labaille, J. (2013). Conception d'un vaccin recombinant contre la maladie de Marek d'après l'étude de la dynamique des populations de variants du vaccin CVI988/RISPENS.
- Lacoste, V. (2007). Diversité génétique et évolution des Gammaherpesvirinae de primates. *Virology*, **11**, 43–62.
- Lee, L. F., Wu, P., Sui, D., Ren, D., Kamil, J., Kung, H. J., & Witter, R. L. (2000). The complete unique long sequence and the overall genomic organization of the GA strain of Marek's disease virus. *PNAS*, **97**, 6091-6096.
- Lee, R. C. (1993). The *C. elegans* Heterochronic Gene *lin-4* Encodes Small RNAs with Antisense Complementarity to *lin-14*. *Cell*, **75**, 843–854.
- Levy, A. M., Burgess, S. C., Davidson, I., Underwood, G., Leitner, G. & Heller, E. D. (2003a). Interferon-containing supernatants increase Marek's disease herpesvirus genomes and gene transcription levels, but not virion replication in vitro. *Viral Immunol.*, **16**, 501-509.
- Li, X.-M., Wang, A.-M., Zhang, J., & Yi, H. (2010). Down-regulation of miR-126 expression in colorectal cancer and its clinical significance. *Medical Oncology*, **28**, 1054-1057.
- Li, X., Wang, F., and Qi, Y. (2014). MiR-126 inhibits the invasion of gastric cancer cell in part targeting Crk. *European Review for Medical and Pharmacological Sciences*, **18**, 2031-2037.
- Maas, H. J. L., Borm, F. & van de Kieft, G. (1982). The Prevention of Marek's Disease in Holland by Vaccination with Cell-Associated Vaccines—CV1988 (DUTCH) and FC126 (USA) Results of comparative Field Trials and Routine Vaccinations of Flocks between 1970-1980. *World's Poultry Sci. J.*, **38**, 163-175.

- McGeoch, D. J., & Gatherer, D. (2005). Integrating Reptilian Herpesviruses into the Family Herpesviridae. *Journal of Virology*, **79**, 725–731.
- McGeoch, D. J., Rixon, F. J., & Davison, A. J. (2006). Topics in herpesvirus genomics and evolution. *Virus Research*, **117**, 90–104.
- Meister, J., and Schmidt H. H. M. (2010). MiR-126 and mir-126*: New players in Cancer. *The Scientific World Journal*, **10**, 2090-2100.
- Messerle, M., Crnkovic, I., Hammerschmidt, W., Ziegler, H., & Koszinowski, U. H. (1997). Cloning and mutagenesis of a herpesvirus genome as an infectious bacterial artificial chromosome. *PNAS*, **94**, 14759–14763.
- Nair, V. & Kung, H.-J. (2004). Marek's disease virus: biology and life cycle. In *Marek's Disease: An evolving Problem*, 62-77. Edited by F. Davison & V. Nair. London: Elsevier Academic Press.
- Nazerian, K. (1973). Oncogenesis of Marek's disease. *Cancer Res.*, **33**, 1427-1430.
- Newcomb, W. W., Homa, F. L., Thomsen, D. R., Booy, F. P., Trus, B. L., Steven, A. C., ... Brown, J. C. (1996). Assembly of the Herpes Simplex Virus Capsid: Characterization of Intermediates Observed During Cell-free Capsid Formation. *J. Mol. Biol.*, **263**, 432–446.
- Okazaki, W., Purchase, H. G. and Burmester, B. R. (1970). Protection against Marek's Disease by Vaccination with a Herpesvirus of Turkeys. *Avian Dis.*, **14**, 413-429.
- Parcells, M. S., Lin, S. F., Dienglewicz, R. L., Majerciak, V., Robinson, D. R., Chen, H. C., Wu, Z., Dubyak, G. R., Brunovskis, P., Hunt, H. D., Lee, L. F. & Kung, H. J. (2001). Marek's disease virus (MDV) encodes an interleukin-8 homolog (vIL-8): characterization of the vIL-8 protein and a vIL-8 deletion mutant MDV. *J Virol.*, **75**, 5159-5173.
- Petherbridge, L., Brown, A. C., Baigent, S. J., Howes, K., Sacco, M. A., Osterrieder, N., & Nair, V. K. (2004). Oncogenicity of Virulent Marek's Disease Virus Cloned as Bacterial Artificial Chromosomes. *Journal of Virology*, **78**, 13376–13380.
- Read, A. F., Baigent, S. J., Powers, C., Kgosana, L. B., Blackwell, L., Smith, L. P., & Nair, V. K (2015). Imperfect Vaccination Can Enhance the Transmission of Highly Virulent Pathogens. *PLOS biology*, **13**, 1–18.
- Davison, A. J., Kurobe, T., Gatherer, D., Cunningham, C., Korf, I., Fukuda, H., & Hedrick, R. P. (2013). Comparative Genomics of Carp Herpesviruses. *Journal of Virology*, **87**, 2908–2922.
- Rispens, B. H., van Vloten, H., Mastenbroek, N., Maas, H. J. & Schat, K. A. (1972a). Control of Marek's disease in the Netherlands. I. Isolation of an avirulent Marek's disease virus (strain CVI 988) and its use in laboratory vaccination trials. *Avian Dis.*, **16**, 108-125.
- Rispens, B. H., van Vloten, H., Mastenbroek, N., Maas, J. L. & Schat, K. A. (1972b). Control of Marek's disease in the Netherlands. II. Field trials on vaccination with an avirulent strain (CVI 988) of Marek's disease virus. *Avian Dis.*, **16**, 126-138.
- Roizman, B. and Pellet, P. E. (2007). The family Herpesviridae: a brief introduction. In *Fields Virology* (fourth ed.), 2480-2499.

- Roizman, B., Carmichael, L. E., Deinhardt F., Nahmias, A. J., Plowright, W., Rapp, R., Sheldrick, P., Takahashi, M., Wolf, K. (1981). Herpesviridae: definition, provisional nomenclature, and taxonomy. *Intervirology*, **16**, 201–217.
- Schat, K. A. & Nair, V. (2008b). Marek's Disease. In *Diseases of Poultry*, 452-514. Edited by Y. M. Saif: Wiley-Blackwell.
- Schat, K. A. and Calnek B. W. (1978). Characterization of an Apparently Nononcogenic Marek's Disease Virus. *Journal of the National Cancer Institute*, **60**, 1075-1082.
- Schumacher, D., Tischer, B. K., Fuchs, W. & Osterrieder, N. (2000). Reconstitution of Marek's disease virus serotype 1 (MDV-1) from DNA cloned as a bacterial artificial chromosome and characterization of a glycoprotein B-negative MDV-1 mutant. *J Virol.*, **74**, 11088-11098.
- Schumacher, D., Tischer, B. K., Fuchs, W., & Osterrieder, N. (2000). Reconstitution of Marek's Disease Virus Serotype 1 (MDV-1) from DNA Cloned as a Bacterial Artificial Chromosome and Characterization of a Glycoprotein B-Negative MDV-1 Mutant., *Journal of Virology*, **74**, 11088–11098.
- Schynts, F., Meurens, F., Muylkens, B., Epstein, A. L., McVoy, M., Thiry, E. (2002). Réplication, clivage-encapsidation et recombinaison de l'ADN des herpèsvirus. *John Libbey Eurotext*, **6**, 343-352.
- Telford, E. A. R., Watson, M. S., Aird, H. C., Perry, J., & Davison, A. J. (1995). The DNA Sequence of Equine Herpesvirus 2. *J. Mol. Biol.*, **249**, 520–528.
- Teng, M., Yu, Z.-H., Zhao, P., Zhuang, G.-Q., Wu, Z.-X., Dang, L., Li, H.-Z., Ma, S.-M., Cui, Z.-Z., Zhang, G.-P., Wu, R., & Luo, J. (2017). Putative roles as oncogene or tumour suppressor of the Midclustered microRNAs in Gallid alphaherpesvirus 2 (GaHV2) induced Marek's disease lymphomagenesis. *Journal of General Virology*, **98**, 1097-1112.
- Trapp, S., Parcels, M. S., Kamil, J. P., Schumacher, D., Tischer, B. K., Kumar, P. M., Nair, V. K. & Osterrieder, N. (2006). A virus-encoded telomerase RNA promotes malignant T cell lymphomagenesis. *J Exp Med.*, **203**, 1307-1317.
- Wildy, P., & Watson, D. H. (1962). Electron Microscopic Studies on the Architecture of Animal Viruses.
- Witter, R. L., Lee, L. F. and Fadly A. M. (1995). Characteristics of CVI988/Rispens and R2/23, Two Prototype Vaccine Strains of Serotype 1 Marek's Disease Virus. *Avian dis.*, **39**, 269-284.
- Witter, R. L. (1997). Increased virulence of Marek's disease virus field isolates. *Avian Dis.*, **41**, 149-163.
- Witter, R. L., & Schat, K. A. (2003). In *In Diseases Poultry* (ed. Y. M. Saif), 11th edn, 407-465. Iowa State Press, Iowa.
- Zhang, J. D., Y.-Y., Lin, Y.-F., Chen, Y., Yang, L., Wang, H.-J., and Ma, D. (2008). The cell growth suppressor, miR-126, targets IRS-1. *Biochemical and Biophysical Research Communications*, **377**, 136-140.