

RESEARCH OUTPUTS / RÉSULTATS DE RECHERCHE

Uniqueness of limit cycles for a class of planar vector fields

Carletti, Timoteo

Published in:
Qualitative Theory of Dynamical Systems

Publication date:
2005

Document Version
Early version, also known as pre-print

[Link to publication](#)

Citation for published version (HARVARD):
Carletti, T 2005, 'Uniqueness of limit cycles for a class of planar vector fields', *Qualitative Theory of Dynamical Systems*, vol. 6, no. 1, pp. 31-43.

General rights

Copyright and moral rights for the publications made accessible in the public portal are retained by the authors and/or other copyright owners and it is a condition of accessing publications that users recognise and abide by the legal requirements associated with these rights.

- Users may download and print one copy of any publication from the public portal for the purpose of private study or research.
- You may not further distribute the material or use it for any profit-making activity or commercial gain
- You may freely distribute the URL identifying the publication in the public portal ?

Take down policy

If you believe that this document breaches copyright please contact us providing details, and we will remove access to the work immediately and investigate your claim.

Uniqueness of limit cycles for a class of planar vector fields.

Timoteo Carletti

Scuola Normale Superiore, piazza dei Cavalieri 7, 56126 Pisa, Italy
E-mail: t.carletti@sns.it

We give sufficient conditions to ensure uniqueness of limit cycles for a class of planar vector fields. We also exhibit a class of examples with exactly one limit cycle.

Key Words: planar vector fields, uniqueness of limit cycles, Liénard-like systems

1. INTRODUCTION

In this paper we consider the problem of determine the number of limit cycles, i.e. isolated closed trajectories, for planar vector fields. This is a classical problem, included as part of the XVI Hilbert's problem. The literature is huge and still growing, for a review see [3] and the more recent [6, 5].

An important subproblem is to study systems with a unique limit cycle, in fact in this case the dynamics of the cycle can “dominate” the global dynamics of the whole system. Let us consider planar vector fields of the form:

$$\dot{x} = \beta(x) [\phi(y) - F(x, y)], \quad \dot{y} = -\alpha(y)g(x), \quad (1)$$

under the regularity assumptions (to ensure the existence and uniqueness of the Cauchy initial problem) for which there exists: $-\infty \leq a < 0 < b \leq +\infty$, such that:

- A1) $\beta \in Lip(a, b)$ and $\alpha \in Lip(\mathbf{R})$;
- A2) $\phi \in Lip(\mathbf{R})$, $g \in Lip(a, b)$ and $F \in C^1((a, b) \times \mathbf{R})$.

Without loss of generality we can assume α and β to be positive in their respective domains of definition, in fact the existence of x_0 such that $\beta(x_0) = 0$ (or y_0 s.t. $\alpha(y_0) = 0$), gives rise to *invariant lines*, which cannot

intersect a limit cycle. Hence we can reparametrize time, by dividing the vector field by: $\alpha(y)\beta(x)$. The transformed system is:

$$\dot{x} = \tilde{\phi}(y) - \tilde{F}(x, y), \quad \dot{y} = -\tilde{g}(x), \quad (2)$$

where $\tilde{\phi}(y) = \phi(y)/\alpha(y)$, $\tilde{F}(x, y) = F(x, y)/\alpha(y)$ and $\tilde{g}(x) = g(x)/\beta(x)$. In the following we will drop out the $\tilde{}$ -mark and consider the general system of previous type.

These systems can be thought as “non-Hamiltonian perturbations” of Hamiltonian ones, with Hamilton function: $H(x, y) = \Phi(y) + G(x)$, where $\Phi(y) = \int_0^y \phi(s) ds$ and $G(x) = \int_0^x g(s) ds$, being $F(x, y)$ the “perturbation”.

One can also consider (2) as “generalized” Liénard equations:

$$\ddot{x} + f(x)\dot{x} + g(x) = 0,$$

which in the Liénard plane can be rewritten as:

$$\dot{x} = y - F(x), \quad \dot{y} = -g(x), \quad (3)$$

where $F'(x) = f(x)$, hence our systems generalize (3) by allowing a dependence of F also on y .

Let $\lambda > 0$ and let us consider the energy level $\mathcal{H}_\lambda = \{(x, y) \in \mathbf{R}^2 : \Phi(y) + G(x) = \lambda\}$, the knowledge of the flow through \mathcal{H}_λ can give informations about the existence of limit cycles. Because

$$\langle \nabla \mathcal{H}_\lambda, X(x, y) \rangle \Big|_{\mathcal{H}_\lambda} = -F(x, y)g(x),$$

where $X(x, y) = (\phi(y) - F(x, y), -g(x))$, no limit cycles can be completely contained in a region where gF doesn't change sign. We will see in a while that the set of zeros of F will play a fundamental role in our construction.

For Liénard systems the set of zeros of F is given by vertical lines $x = x_k$ s.t. $F(x_k) = 0$. In a recent paper [2] authors, using ideas taken from Liénard systems [1], proved a uniqueness result for systems (2) assuming that $F(x, y)$ vanishes only at three vertical lines $x = x_- < 0$, $x = 0$ and $x = x_+ > 0$. We generalize this condition by assuming that zeros of $F(x, y)$ lie on (quite) general curves. More precisely let us assume:

B0) $F(0, y) = 0$ for all real y ;

and moreover there exist \mathcal{C}^1 functions $\psi_j : \mathbf{R} \rightarrow \mathbf{R}$, $j \in \{1, 2\}$, such that ¹:

¹We remark that our main result still holds, even if one assume there exist $\alpha_j < 0 < \beta_j$, $j \in \{1, 2\}$, and the functions ψ_j to be defined in $[\alpha_j, \beta_j]$ and verify hypotheses B) on their new domain of definition.

B1) $y \mapsto \psi_1(y)$, is *positive* for all $y \in \mathbf{R}$, $y\psi_1'(y) < 0$ for all $y \neq 0$, $\psi_1(0) < b$;

B2) $y \mapsto \psi_2(y)$, is *negative* for all $y \in \mathbf{R}$, $y\psi_2'(y) > 0$ for all $y \neq 0$, $\psi_2(0) > a$;

B3) for all $y \in \mathbf{R}$, $j \in \{1, 2\}$, we have:

$$F(\psi_j(y), y) \equiv 0,$$

these curves will be called “non-trivial zeros” of $F(x, y)$ (in opposition with the trivial zeros given by $x = 0$).

Let us divide the strip $(a, b) \times \mathbf{R}$ into four distinct domains:

- $D_1^> := \{(x, y) \in (a, b) \times \mathbf{R} : x > \psi_1(y)\}$;
- $D_1^< := \{(x, y) \in (a, b) \times \mathbf{R} : 0 < x < \psi_1(y)\}$;
- $D_2^> := \{(x, y) \in (a, b) \times \mathbf{R} : \psi_2(y) < x < 0\}$;
- $D_2^< := \{(x, y) \in (a, b) \times \mathbf{R} : x < \psi_2(y)\}$.

The following assumptions generalize “standard sign ones”:

C1) $y\phi(y) > 0$ for all $y \neq 0$ and $xg(x) > 0$ for all $x \in (a, b) \setminus \{0\}$;

C2) $g(x)F(x, y) < 0$ for all $(x, y) \in D_1^< \cup D_2^>$.

We remark that hypothesis C2) can be weakened into:

C2') $g(x)F(x, y) \leq 0$ for all $(x, y) \in D_1^< \cup D_2^>$ except at some (x_0, y_0) where strictly inequality holds.

With these hypotheses we ensure that $(0, 0)$ is the only singular point in the strip $(a, b) \times \mathbf{R}$ of system (2). We are now able to state our main result

THEOREM 1. *Let us consider system (2) and let us assume Hypotheses A), B) and C) to hold. Then there is at most one limit cycle which intersects both curves $x = \psi_1(y)$ and $x = \psi_2(y)$ contained in $(a, b) \times \mathbf{R}$, provided:*

D1) the function $y \mapsto F(x, y)/\phi(y)$ is strictly increasing for $(x, y) \in D_1^<$ and $y \neq 0$;

D2) the function $y \mapsto F(x, y)/\phi(y)$ is strictly decreasing for $(x, y) \in D_2^>$ and $y \neq 0$;

E) the function $x \mapsto F(x, y)$ is positive in $D_1^>$, negative in $D_2^<$ and increasing in $D_1^> \cup D_2^<$;

F) let $A_j(y) = [\phi(y)\partial_x F(x, y) - g(x)\partial_y F(x, y)] \Big|_{x=\psi_j(y)}$, then $A_j(y) y > 0$ for $y \neq 0$, $j \in \{1, 2\}$.

G) there exists a function $\zeta : [\psi_2(0), \psi_1(0)] \rightarrow \mathbf{R}$ such that

$$\phi(\zeta(x)) - F(x, \zeta(x)) = 0 .$$

Hypotheses D) and E) naturally generalize hypotheses used in the Liénard case [1] or in the more general situation studied in [2]. Also hypothesis F) is very natural: each closed trajectory intersects the non-trivial zeros of $F(x, y)$ at most once in any quadrant. We remark that this condition is trivially verified if the functions ψ_j are indentially constant, namely in the case considered in [2].

The proof of Theorem 1 will be given in the next section. In the last section (§ 3) we will provide a family of systems with exactly one limit cycle. This family is a “natural generalization” of the classical cubic Van der Pol case, thus our result can be considered as a natural extension of this classical existence and uniqueness result.

Acknowledgment I would like to thank the anonymous referee for some useful remarks allowing me to improve a first version of this paper.

2. PROOF OF THEOREM 1

The aim of this section is to prove our main result Theorem 1. The proof is based on the following remark,

Remark 2. Along any closed curve $\gamma : [0, T] \rightarrow (a, b) \times \mathbf{R}$ one has:

$$\int_0^T \frac{d}{dt} H \Big|_{\text{flow}} \circ \gamma(s) ds = H \circ \gamma(T) - H \circ \gamma(0) = 0 ,$$

moreover if γ is an integral curve of system (2) we can evaluate the integrand function to obtain:

$$I_\gamma := \int_0^T g(x_\gamma(s)) F(x_\gamma(s), y_\gamma(s)) ds = 0 , \quad (4)$$

where $\gamma(s) = (x_\gamma(s), y_\gamma(s))$.

The uniqueness result will be proved by showing that the existence of two limit cycles, γ_1 contained² in γ_2 , both intersecting $x = \psi_1(y)$ and $x = \psi_2(y)$, will imply: $I_{\gamma_1} < I_{\gamma_2}$, which contradicts (4).

From now on we will assume the existence of two limit cycles, γ_1 contained in γ_2 , which intersect both non-trivial zeros of F .

²By this we mean γ_1 is properly contained in the compact set whose boundary is γ_2 .

Let us now consider the set of zeros of the equation: $\phi(y) - F(x, y) = 0$ inside $D_1^< \cup D_2^>$. By hypothesis G) this is the graph of some function $x \mapsto \zeta(x)$, moreover this function vanishes for $x \in \{\psi_2(0), 0, \psi_1(0)\}$, it is positive for $x \in (\psi_2(0), 0)$ and negative for $x \in (0, \psi_1(0))$.

The sign properties of ζ can be proved as follows. Let $\psi_2(0) < x < 0$, then by C2) $0 < F(x, \zeta(x)) = \phi(\zeta(x))$, using now C1) we conclude that $\zeta(x) > 0$. The case $0 < x < \psi_1(0)$ can be handle similarly and we omit. By continuity we get the result about the zeros of $\zeta(x)$.

Hypothesis F) guarantees that a closed trajectory can intersect the non-trivial zeros of $F(x, y)$ only once in each quadrant, in fact $A_j(y)$ gives a measure of the angle between the vector field and the normal to $\mathcal{F}_0 = \{(x, y) : x = \psi_1(y)\} \cup \{(x, y) : x = \psi_2(y)\}$ at $(\psi_j(y), y)$:

$$\begin{aligned} \langle \nabla \mathcal{F}_0, X(x, y) \rangle \Big|_{\mathcal{F}_0} &= [\phi(y)\partial_x F(x, y) - g(x)\partial_y F(x, y)] \Big|_{\mathcal{F}_0} \\ &= A_j(y) \quad j \in \{1, 2\}. \end{aligned}$$

For instance, because the angle between the vector field and $\{(x, y) : x = \psi_1(y)\} \cap \{y > 0\}$ is in absolute value smaller than $\pi/2$, a trajectory starting at $(0, \bar{y})$, for some $\bar{y} > 0$, which will intersect $\{(x, y) : x = \psi_1(y)\} \cap \{y > 0\}$, could not meet anew $\{(x, y) : x = \psi_1(y)\} \cap \{y > 0\}$.

From hypotheses D) and the sign of F on $D_2^> \cup D_1^<$, it follows easily that for all $(x, y) \in D_2^> \cup D_1^<$ one has: $(y - \zeta(x))(\phi(y) - F(x, y)) > 0$. Hence a cycle intersects $(D_2^> \cup D_1^<) \cap \{y > 0\}$ in a region where $\phi(y) - F(x, y) > 0$, whereas the intersection with $(D_2^> \cup D_1^<) \cap \{y < 0\}$ holds where $\phi(y) - F(x, y) < 0$. This remark allows us to divide the path of integration needed to evaluate I_{γ_j} , $j \in \{1, 2\}$, in two parts: an ‘‘horizontal’’ one where $\dot{x} > 0$ and a ‘‘vertical’’ one, where \dot{x} vanishes, to be more clear look at Figure 1 where $D_i A_i$ and $B_i C_i$ are horizontal arcs, whereas $C_i D_i$ and $A_i B_i$ are vertical ones.

Let us define (see Figure 1), for $j \in \{1, 2\}$, A_j (respectively B_j) the intersection point of γ_j with $x = \psi_1(y)$ for $y > 0$ (respectively $y < 0$), and C_j (respectively D_j) the intersection point of γ_j with $x = \psi_2(y)$ for $y < 0$ (respectively $y > 0$). Let also introduce, A_* being the intersection point of γ_1 and the line $x = x_{A_2}$ contained in the first quadrant, and A_{**} being the intersection point of γ_2 and the line $y = y_{A_1}$ contained in the first quadrant. Similarly we introduce points: B_* , B_{**} , C_* , C_{**} and D_* , D_{**} (see Figure 1).

According to this subdivision of the arcs of limit cycles, we evaluate I_{γ_j} as follows:

$$I_{\gamma_1} = \int_{D_* A_*} + \int_{A_* A_1} + \int_{A_1 B_1} + \int_{B_1 B_*} + \int_{B_* C_*} + \int_{C_* C_1} + \int_{C_1 D_1} + \int_{D_1 D_*},$$

$$I_{\gamma_2} = \int_{D_2 A_2} + \int_{A_2 A_{**}} + \int_{A_{**} B_{**}} + \int_{B_{**} B_2} + \int_{B_2 C_2} + \int_{C_2 C_{**}} + \int_{C_{**} D_{**}} + \int_{D_{**} D_2} \quad (5)$$

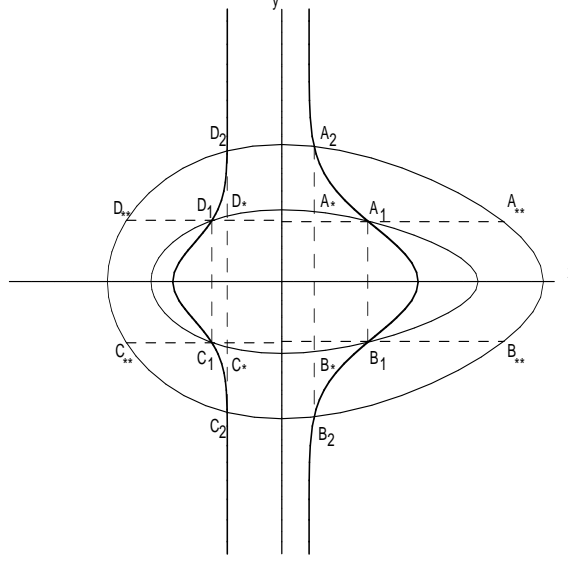

FIG. 1. The non-trivial zeros of F (thick), the limit cycles γ_1 and γ_2 (thin) intersecting both non-trivial zeros of F and their subdivision into arcs.

Let now show that $I_{\gamma_1} < I_{\gamma_2}$, which prove the contradiction and conclude the proof.

2.1. Integration along “horizontal arcs”.

Because along horizontal arcs we have $\dot{x} \neq 0$, we can change integration variable from t to x , hence for example:

$$\int_{D_j A_j} g(x)F(x, y) dt = \int_{x_{D_j}}^{x_{A_j}} \frac{g(x)F(x, y_j(x))}{\phi(y_j(x)) - F(x, y_j(x))} dx,$$

where $y_j(x)$, $j \in \{1, 2\}$, is the parametrization of γ_j as graph over x for $x \in (x_{D_j}, x_{A_j})$.

Because $y_2(x) > y_1(x)$ for all $x \in (x_{D_*}, x_{A_*})$, using hypotheses D) and the sign assumptions C) we get:

$$\frac{g(x)F(x, y_1(x))}{\phi(y_1(x)) - F(x, y_1(x))} < \frac{g(x)F(x, y_2(x))}{\phi(y_2(x)) - F(x, y_2(x))},$$

hence:

$$\begin{aligned} & \int_{x_{D_1}}^{x_{A_1}} \frac{g(x)F(x, y_1(x))}{\phi(y_1(x)) - F(x, y_1(x))} dx < \int_{x_{D_1}}^{x_{D_*}} \frac{g(x)F(x, y_1(x))}{\phi(y_1(x)) - F(x, y_1(x))} dx + \\ & + \int_{x_{A_*}}^{x_{A_1}} \frac{g(x)F(x, y_1(x))}{\phi(y_1(x)) - F(x, y_1(x))} dx + \int_{x_{D_2}}^{x_{A_2}} \frac{g(x)F(x, y_2(x))}{\phi(y_2(x)) - F(x, y_2(x))} dx \\ & \leq \int_{x_{D_2}}^{x_{A_2}} \frac{g(x)F(x, y_2(x))}{\phi(y_2(x)) - F(x, y_2(x))} dx, \end{aligned} \quad (6)$$

the last step follows because the integrand function is negative by hypothesis C2) and from the previous discussion on the sign of $\phi(y) - F(x, y)$.

In a very similar way we can prove that:

$$\int_{x_{B_1}}^{x_{C_1}} \frac{g(x)F(x, y_1(x))}{\phi(y_1(x)) - F(x, y_1(x))} dx < \int_{x_{B_2}}^{x_{C_2}} \frac{g(x)F(x, y_2(x))}{\phi(y_2(x)) - F(x, y_2(x))} dx. \quad (7)$$

2.2. Integration along “vertical arcs”.

Along vertical arcs \dot{y} never vanishes, hence we can perform the integration with respect to the y variable and getting for example:

$$\int_{A_j B_j} g(x)F(x, y) dt = \int_{y_{B_j}}^{y_{A_j}} F(x_j(y), y) dy,$$

where $x_j(y)$, $j \in \{1, 2\}$, is the parametrization of γ_j as graph over y for $y \in (y_{B_j}, y_{A_j})$.

Because $x_2(y) > x_1(y)$ for all $y \in (y_{A_{**}}, y_{B_{**}})$, from hypothesis E) and the definition of A_{**} and B_{**} , we get:

$$\int_{y_{B_1}}^{y_{A_1}} F(x_1(y), y) dy < \int_{y_{B_{**}}}^{y_{A_{**}}} F(x_2(y), y) dy.$$

Again from the sign assumption on F in $D_1^>$, we get:

$$\int_{y_{A_{**}}}^{y_{A_2}} F(x_2(y), y) dy > 0 \quad \text{and} \quad \int_{y_{B_2}}^{y_{B_{**}}} F(x_2(y), y) dy > 0,$$

hence we obtain:

$$\int_{y_{B_1}}^{y_{A_1}} F(x_1(y), y) dy < \int_{y_{B_2}}^{y_{A_2}} F(x_2(y), y) dy. \quad (8)$$

Analogously we can prove that:

$$\int_{y_{C_1}}^{y_{D_1}} F(x_1(y), y) dy < \int_{y_{C_2}}^{y_{D_2}} F(x_2(y), y) dy. \quad (9)$$

2.3. Conclusion of the proof.

We are now able to complete our proof. In fact from (6) and (7) of § 2.1, from (8) and (9) of § 2.2 and the subdivision (4) we get:

$$I_{\gamma_1} < I_{\gamma_2},$$

which contradicts (4), and so the Theorem is proved.

3. A SYSTEM WITH EXACTLY ONE LIMIT CYCLE

In this last part we present a class of examples exhibiting exactly one limit cycle, which turn out to be a natural generalization, in the case where F depends on both x and y , of the classical cubic Van der Pol case.

Let us assume that F has the following “special form”:

$$F(x, y) = x [x - \psi_1(y)] [x - \psi_2(y)], \quad (10)$$

where $(\psi_j)_{j=1,2}$ verify hypotheses B). We observe that for this particular dependence of F on x and y , hypothesis F) is equivalent to the following one:

F') the function $y \mapsto \Phi(y) + G(\psi_j(y))$ is strictly increasing for positive y and strictly decreasing for negative ones, $j \in \{1, 2\}$.

In fact we have:

$$\begin{aligned} A_1(y) &= \psi_1(y) [\psi_1(y) - \psi_2(y)] [\phi(y) + g(\psi_1(y))\psi_1'(y)] \\ &= \psi_1(y) [\psi_1(y) - \psi_2(y)] \frac{d}{dy} [\Phi(y) + G(\psi_1(y))], \end{aligned}$$

and the claim follows from the sign properties of ψ_j and the definitions of Φ and G . Similarly for A_2 .

In the rest of the section we will consider the following concrete example given by:

$$\begin{aligned} \phi(y) = y, \quad g(x) = x, \quad \psi_1(y) = c_1 e^{-d_1 y^2} + e_1 \quad \text{and} \\ \psi_2(y) = -c_2 e^{-d_2 y^2} - e_2, \end{aligned} \quad (11)$$

with c_j, d_j , and e_j positive real numbers such that:

- (1) $c_1 + e_1 = c_2 + e_2 = r$,
- (2) $c_1 \geq c_2$ and $d_1 \geq d_2$,
- (3) $c_1 d_1 \max\{r, r^2\} < 1/2$.

The remaining part of the section will be devoted to prove the existence of exactly one limit cycle. The proof will be achieved by showing that all, eventually, limit cycles must intersect both non-trivial zeros of F , then proving the existence of at least a limit cycle, we will conclude using Theorem 1.

We left to the reader the easy check that with the above hypotheses, system (11) with F given by (10) satisfies all hypotheses of Theorem 1.

We claim that the vector field is transversal (pointing outward) to the circle $\mathcal{C}_\rho = \{(x, y) \in \mathbf{R}^2 : x^2 + y^2 = \rho^2\}$, with $\rho \leq r = c_1 + e_1$; thus it can be used as inner boundary of a Poincaré–Bendixson domain. Moreover this circle passes through the points $(\psi_1(0), 0)$, $(\psi_2(0), 0)$, because $r = \psi_1(0) = -\psi_2(0)$, and it lies inside the domain $D_2^> \cup D_1^<$ (just check the curvature of the circle and of the non-trivial zeros of F at these common points, by using (2) and (3)). Hence all orbits, and thus also all eventually limit cycles, must intersect both non-trivial zeros of F .

To conclude it will be enough to prove the existence of at least a limit cycle. To do this we will construct the outer boundary of a Poincaré–Bendixson domain by using *phase–plane comparison techniques*. The proof will be divided into three parts, each one considering the regions of phase–plane where pieces of orbits lie.

3.1. Comparing flows for positive x

Let $\phi_0(x) = F(x, 0) = x(x^2 - r^2)$ and let us compare the flow of the vector field X , given in coordinates by:

$$\dot{x} = y - x[x - \psi_1(y)][x - \psi_2(y)], \quad \dot{y} = -x, \quad (12)$$

where $(\psi_j(y))_{j=1,2}$ are given by (11), with the (Liénard) vector field X_0 :

$$\dot{x} = y - \phi_0(x), \quad \dot{y} = -x. \quad (13)$$

The latter system has [4] one and only one attracting limit cycle, Γ_0 , (which intersect both zeros of $\phi_0(x) = 0$, i.e. $x = \pm r$). Let $\gamma_0(t)$ be a trajectory of this vector field lying outside Γ_0 (i.e. contained in the unbounded domain whose boundary is Γ_0), passing by the points $A = (r', y_A)$, $y_A > 0$, and $A_0 = (r', y_{A_0})$, $y_{A_0} < 0$, where $r' = r + \epsilon$, for some fixed $\epsilon > 0$ (see Figure 2). Let $y_A + y_{A_0} = \Delta$, because the cycle is attracting we have $\Delta > 0$, a simple bound is given by $\Delta \geq 2\epsilon r'(r' + \epsilon)$.

To compare the slopes of the vector fields (12) and (13) we need to estimate $F(x, y) - \phi_0(x)$ for $x > 0$; this will be done in the following lemma

LEMMA 3. *Let $F(x, y) = x[x - \psi_1(y)][x - \psi_2(y)]$, where $(\psi_j(y))_{j=1,2}$ are given by (11), and let $\phi_0(x) = x(x - \psi_1(0))(x - \psi_2(0))$. Assume moreover hypotheses (1), (2) and (3) to hold, then:*

$$F(x, y) - \phi_0(x) > 0, \quad (14)$$

for all $x > 0$ and $y \in \mathbf{R}$.

Proof. A direct computation gives:

$$F(x, y) - \phi_0(x) = -x^2[\psi_1(y) + \psi_2(y)] + x[\psi_1(y)\psi_2(y) + r^2]. \quad (15)$$

Using the form of $(\psi_j(y))_{j=1,2}$ given by (11), the last term in the right hand side can be rewritten as:

$$\begin{aligned} \psi_1(y)\psi_2(y) + r^2 &= c_1c_2\left(1 - e^{-(d_1+d_2)y^2}\right) + c_1e_2\left(1 - e^{-d_1y^2}\right) \\ &\quad + e_1c_2\left(1 - e^{-d_2y^2}\right), \end{aligned}$$

thus by the sign assumptions on $(c_j)_{j=1,2}$, $(d_j)_{j=1,2}$ and $(e_j)_{j=1,2}$, we conclude that this term is always non-negative and zero only for $y = 0$.

Recalling that $c_1 + e_1 = c_2 + e_2$, the remaining term in (15) can be rewritten as:

$$\begin{aligned} \psi_1(y) + \psi_2(y) &= -c_1\left(1 - e^{-d_1y^2}\right) + c_2\left(1 - e^{-d_2y^2}\right) \\ &\leq (c_1 - c_2)\left(e^{-d_2y^2} - 1\right) \leq 0, \end{aligned}$$

where the inequality follows by hypothesis (2).

We hence conclude that:

$$F(x, y) - \phi_0(x) = -x^2[\psi_1(y) + \psi_2(y)] + x[\psi_1(y)\psi_2(y) + r^2] > 0,$$

for all positive x and all $y \neq 0$ ■

The slope of the vector field (12) is $\left.\frac{dy}{dx}\right|_X = \frac{-x}{y-F(x,y)}$, whereas the one for (13) is $\left.\frac{dy}{dx}\right|_{X_0} = \frac{-x}{y-\phi_0(x)}$, thus the previous lemma ensures that for $x > 0$ one has:

$$\left.\frac{dy}{dx}\right|_X < \left.\frac{dy}{dx}\right|_{X_0}, \quad (16)$$

namely orbits of X lying in $x > 0$ enter orbits of X_0 (see Figure 2).

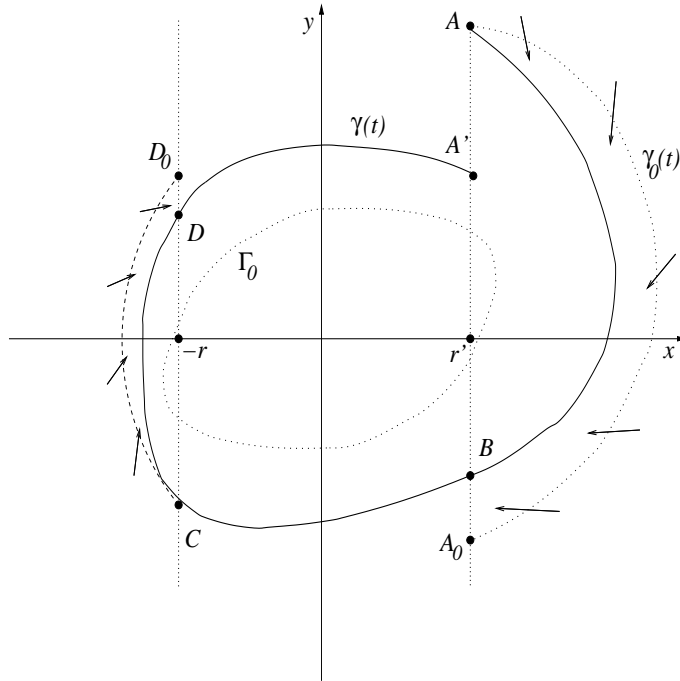

FIG. 2. Construction of the outer boundary of a Poincaré–Bendixson domain. We show the attracting limit cycle of X_0 , Γ_0 , and part of one of its orbits from A to A_0 , $\gamma_0(t)$ (dotted curves). The dashed curve from C to D_0 , is a piece of the circle C_r . Solid curves AB , BC , CD and DA' are trajectories of X , $\gamma(t)$. Arrows denote the vector field X across the orbit AA_0 and CD_0 . BC and DA' are the so-called “horizontal arcs”.

3.2. Comparing flows for negative x

Orbits lying in $x < 0$ are controlled with the following remark. $F(x, y)$ is negative for $x < -r$ and all $y \in \mathbf{R}$, thus comparing the flow of X through circles $\mathcal{C}_\rho = \{(x, y) \in \mathbf{R}^2 : x^2 + y^2 = \rho^2\}$, with $\rho > r$, we get:

$$\frac{d}{dt}\mathcal{C}_\rho = -xF(x, y) < 0 \quad x < 0, y \in \mathbf{R},$$

hence the orbit passing through $C = (-r, y_C)$, $y_C < 0$, will reach again the vertical line $x = -r$ at some $D = (-r, y_D)$, $y_D > 0$, and moreover $y_D < |y_C|$.

3.3. Comparing flows for “horizontal arcs”

The following lemma allows us to control “horizontal arcs” of trajectories (see Figure 2):

LEMMA 4. *The orbit starting at $D = (-r, y_D)$, $y_D > 0$, will reach the y -axis and then the point $A' = (r', y_{A'})$, $y_{A'} > 0$. Moreover $|y_D - y_{A'}|$ can be made as small as we want taking sufficiently large y_D .*

We observe that a similar result holds for orbits lying in $y < 0$ connecting B to C .

3.4. Conclusion of the proof

We are now able to conclude our proof by constructing the outern boundary of a Poincaré–Bendixson domain. Let δ be a positive number such that $\delta < \Delta/2$, where Δ has been introduced in § 3.1. Assume moreover, see Lemma 4, that $|y_D - y_{A'}| < \delta$ and $|y_B - y_C| < \delta$, then we can prove that orbits of X will approach the origin when winding around it:

$$y_A - y_{A'} = y_A - y_D + (y_D - y_{A'}) > y_A + y_C - \delta$$

where we used the closeness of y_D and $y_{A'}$ and the relation $-y_D > y_C$, moreover

$$y_A + y_C - \delta = y_A + y_B + (y_C - y_B) - \delta > \Delta - 2\delta > 0,$$

where again we used the closeness of y_C and y_B . Thus $y_A - y_{A'} > 0$ and the construction of an outern Poincaré–Bendixson boundary is achieved. This allows us to prove the existence of at least one limit cycle, which intersects both curves $x = \psi_j(y)$, $j = 1, 2$, hence by Theorem 1 we conclude that this limit cycle is indeed unique.

In Figure 3 we present a numerical example, to show an application of Theorem 1.

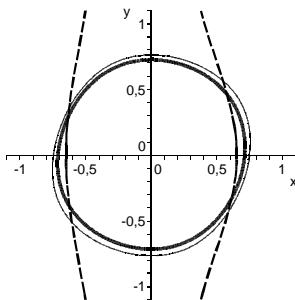

FIG. 3. An example with $c_1 = 0.4$, $e_1 = 0.25$, $d_1 = 0.95$, $c_2 = 0.25$, $e_2 = 0.4$, $d_2 = 0.75$. We numerically compute the attracting unique limit cycle (thick) of X , the unique attracting limit cycle of X_0 (thin) and non-trivial zeros of F (dashed thick).

REFERENCES

1. T. CARLETTI AND G. VILLARI: *A note on existence and uniqueness of limit cycles for Liénard systems*, J. Math. Anal. Appl. **307** (2005), pp. 763–773.
2. M. SABATINI AND G. VILLARI, *About limit cycle's uniqueness for a class of generalized Liénard systems*, preprint number **672**, Univ. Trento (2004).
3. R. CONTI AND G. SANSONE, *Non-linear differential equations*, Pergamon Press, (1964).
4. G. SANSONE, *Sopra l'equazione di Liénard delle oscillazioni di rilassamento*, Ann. Mat. Pura Appl. (4) **28** (1949), pp. 153–181.
5. YE YANQUA ET AL., *Theory of limit cycles*, Trans. Math. Monog., Vol. 66, Americ. Math. Soc., Providence, Rhode Island, (1986).
6. ZHANG ZHI-FEN ET AL., *Qualitative Theory of differential equations*, Trans. Math. Monog., Vol. 101, Americ. Math. Soc., Providence, Rhode Island, (1992).